

Manual 28 + 40STE SE

2+1 SPEED

12V & 24V

GENEREL INFORMATION

MOUNTING INSTRUCTION

EXPLODED VIEW

PARTS LIST

CONNECTING DIAGRAM

WIRE DIMENSION AND FUSE SIZE

WORLD WIDE DISTRIBUTION LIST



SERIAL NO: PS _____

ANDERSEN
STAINLESS STEEL WINCHES



CONGRATULATIONS

You have purchased an ANDERSEN high quality winch. This product is a result of many years of development and experience in producing winches for sailboats. This winch gives you a high degree of functionality and many years of safe and easy sail handling.

GENERAL INFORMATION

PLEASE READ THIS BEFORE INSTALLING YOUR ANDERSEN ELECTRIC WINCH.

The electric ANDERSEN winch has some built-in advantages:

- Easy to fit on your boat.
- Template included.
- Special tools included.
- Electric unit is turnable in 8 horizontal steps (45°).
- Easy to dismantle. Winch and electric unit can be dismantled separately.
- Winch is in the usual high **ANDERSEN** quality, featuring drum, roller bearings etc. of stainless steel.
- Always the possibility of manual (2 speed) drive, just by inserting a standard winch handle. No shift-bottom of any kind.
- MODULAR POWER SYSTEM©: It is possible to exchange the 2+1 SE electric drive unit with a Compact© electric drive unit.

Mounting Installation:

Please follow the mounting instructions.

Ensure that each hole in the deck is bedded, including the big hole in the center.

IMPORTANT: Be careful not to put bedding compound IN the thread holes in the deck plate.

Ensure that the sealing ring (O-ring) on top of the gear unit is placed in its groove.

Electric Installation:

Please follow the mounting instructions.

WARNING: Do not use smaller wire, than recommended in the diagram. This can cause malfunction of the winch and in worst case - FIRE. The wires should always be as short as possible.

Normal Use:

The electric motor has built-in overload circuit breaker, which breaks the circuit, before the motor gets too hot.

After a short period of cooling, depending on temperature under deck, ventilation etc., the winch will be ready for electrical operation again.

Meanwhile, if necessary, just insert a standard winch handle, and use the winch as a 2 speed manual winch.

We recommend to remove the handle when operated electrically - from a safety point of view.

General Service Instructions:

The electric drive unit is lubricated sealed and requires no further maintenance.

The part *on* deck is a standard self tailing winch, and needs regular service. We recommend dismantling, cleaning and lubrication *once* a year. Under extensive use, such as racing, charter or blue water sailing, we recommend to make a further lubrication check during the one year period.

We strongly recommend always to use ANDERSEN WINCH GREASE© when lubricating your winch.

ANDERSEN WINCH GREASE© is a high quality silicone/Teflon® grease.



MOUNTING INSTRUCTION

28 + 40 STE SE
2+1 SPEED

FIG.1

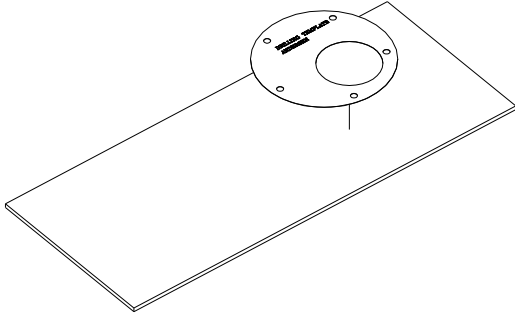

FIG.2

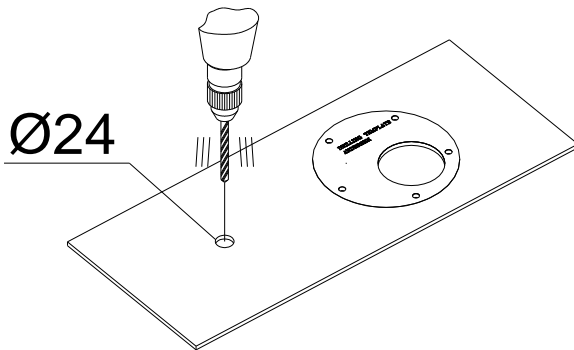

FIG.4

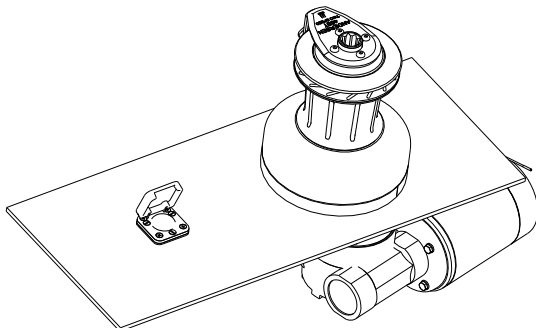
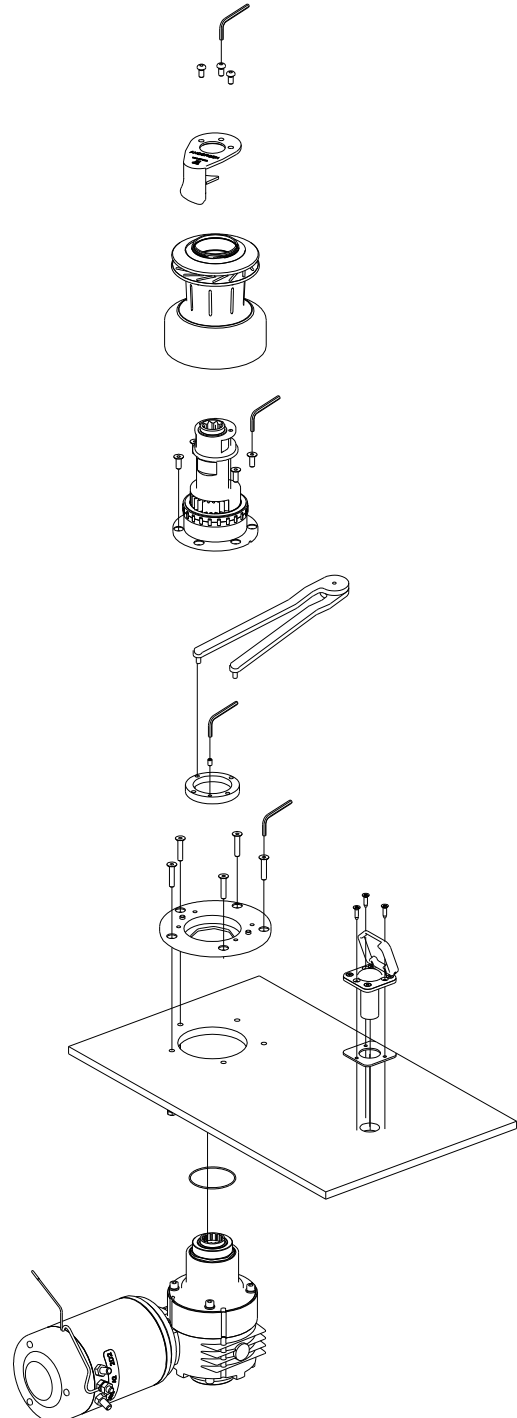

FIG.3



IMPORTANT INSTALLATION INFORMATION!

It is extremely important that your motor is aligned with your winch. Non-aligned motors will be noisy and gear wear will be accelerated.

To insure that your motor is aligned properly the motor flange must be flush with the deck plate and the eight-sided nut must fit snugly into the octagon in the deck plate.

This can be achieved with the help of the following:

- Drill the hole through the deck wider than the motor flange. When mounted there must be free space between the deck and the flange.
- Clean the deck hole before attempting to install the motor so that the motor flange does not catch splinters of fiberglass or wood when being inserted through the deck.
- Insure that the underside of the deck plate is clean and free from resin, varnish or sealants.
- Do not use a sealant between the flange and deck plate. An o-ring insures a waterproof connection. Extra waterproofing can be achieved by applying sealant to the top of the deck plate next to the mounting nut after installation.
- Insure that the locking screw on the mounting nut is not protruding beyond the contact surface before tightening the mounting nut. Tighten the locking screw when the mounting nut is securely in place.

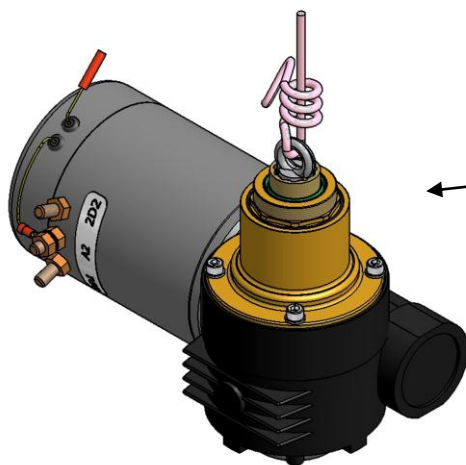
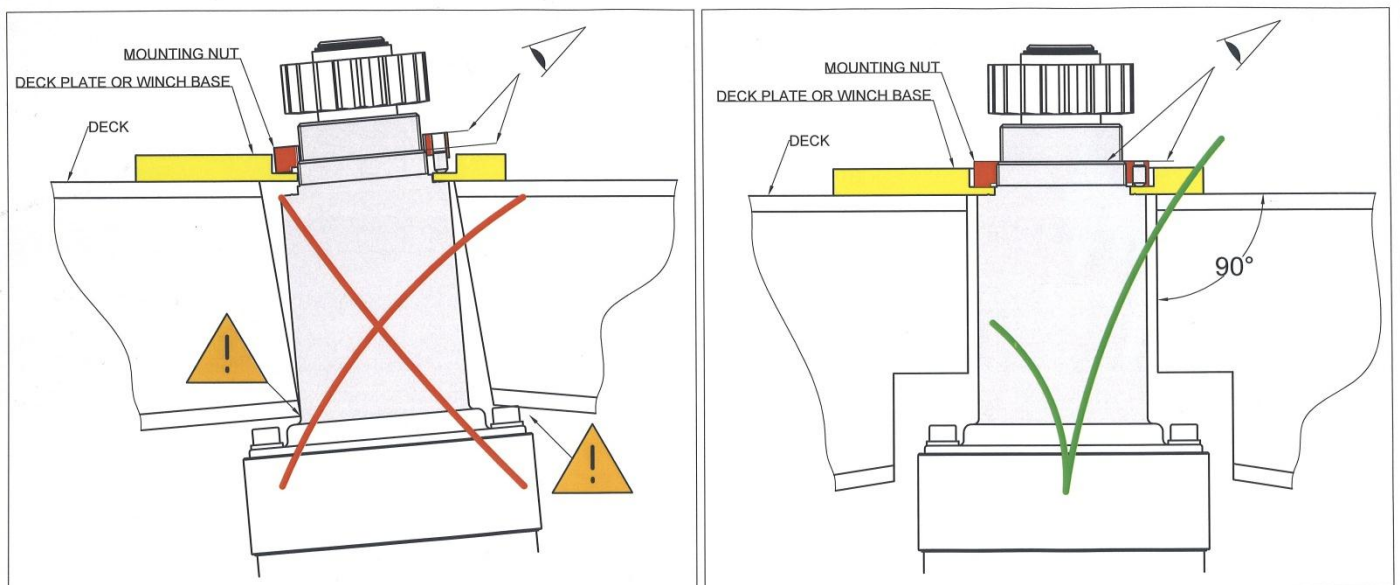

FOR GEARUNITS OF THIS TYPE, USE OF LIFTING DEVICE IS RECOMMENDED

INSTALLATION DIMENSIONS

28 STE SE

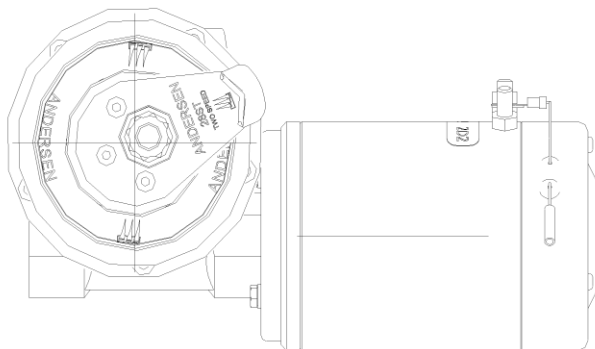
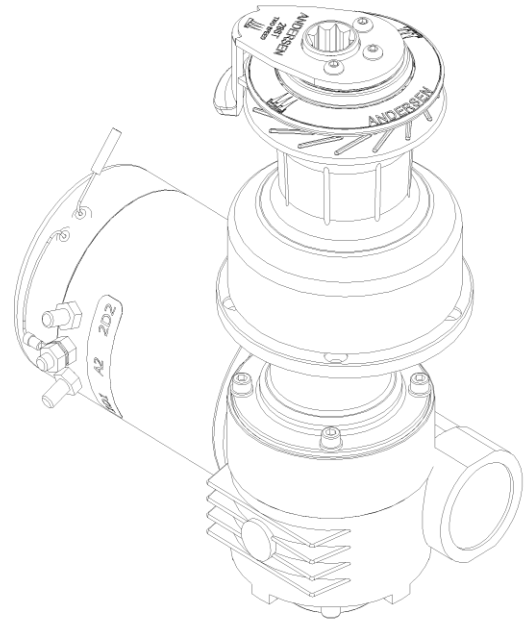
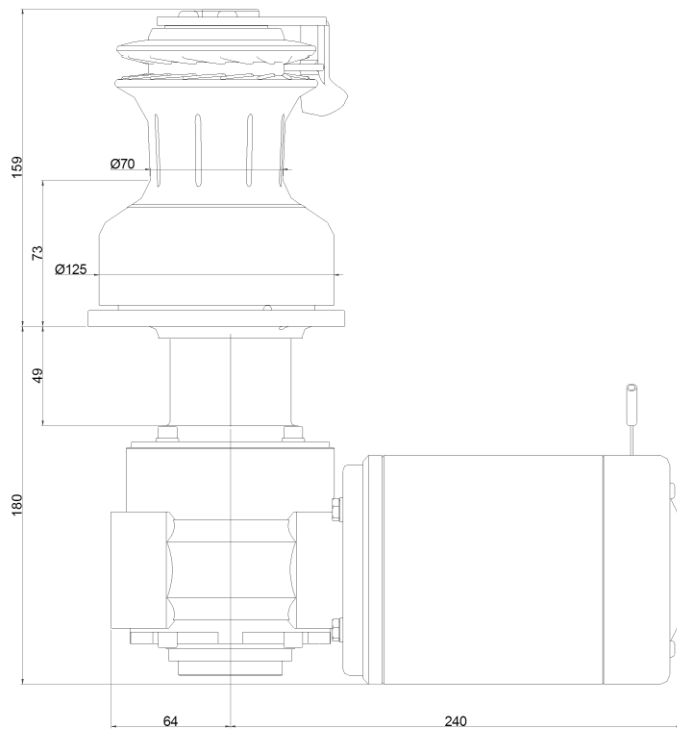

(Non-dimensional accuracy)



INSTALLATION DIMENSIONS

40 STE SE

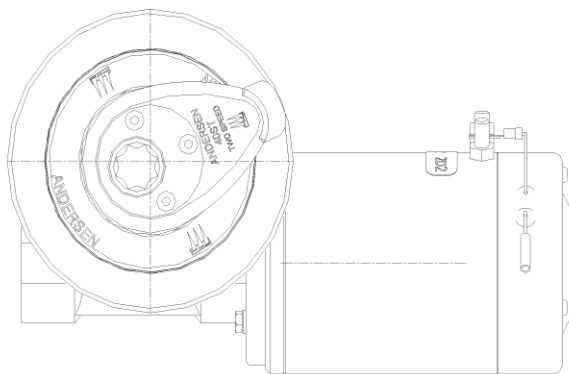
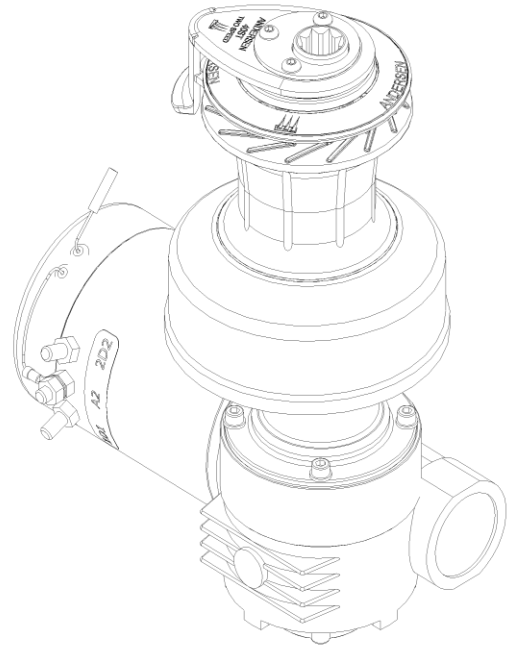
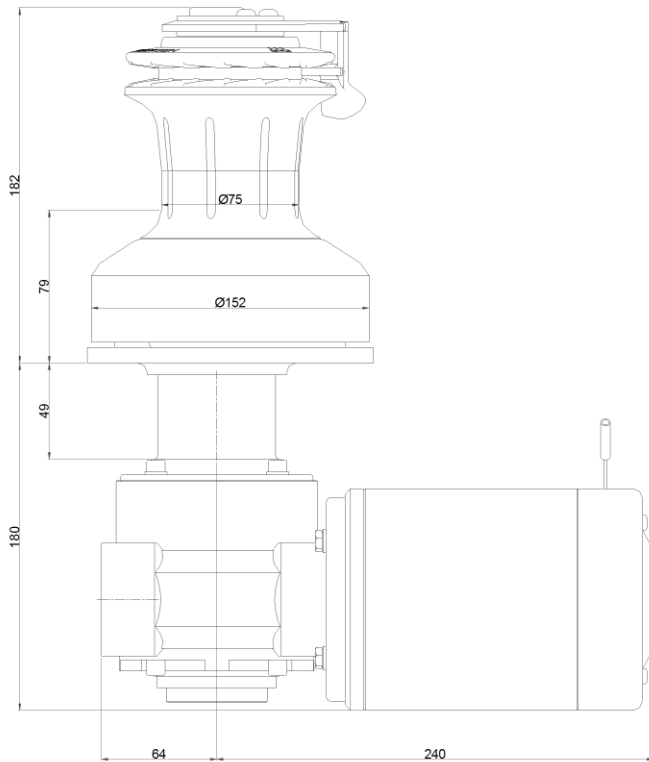

(Non-dimensional accuracy)



DRILLING TEMPLATE

28 STE SE

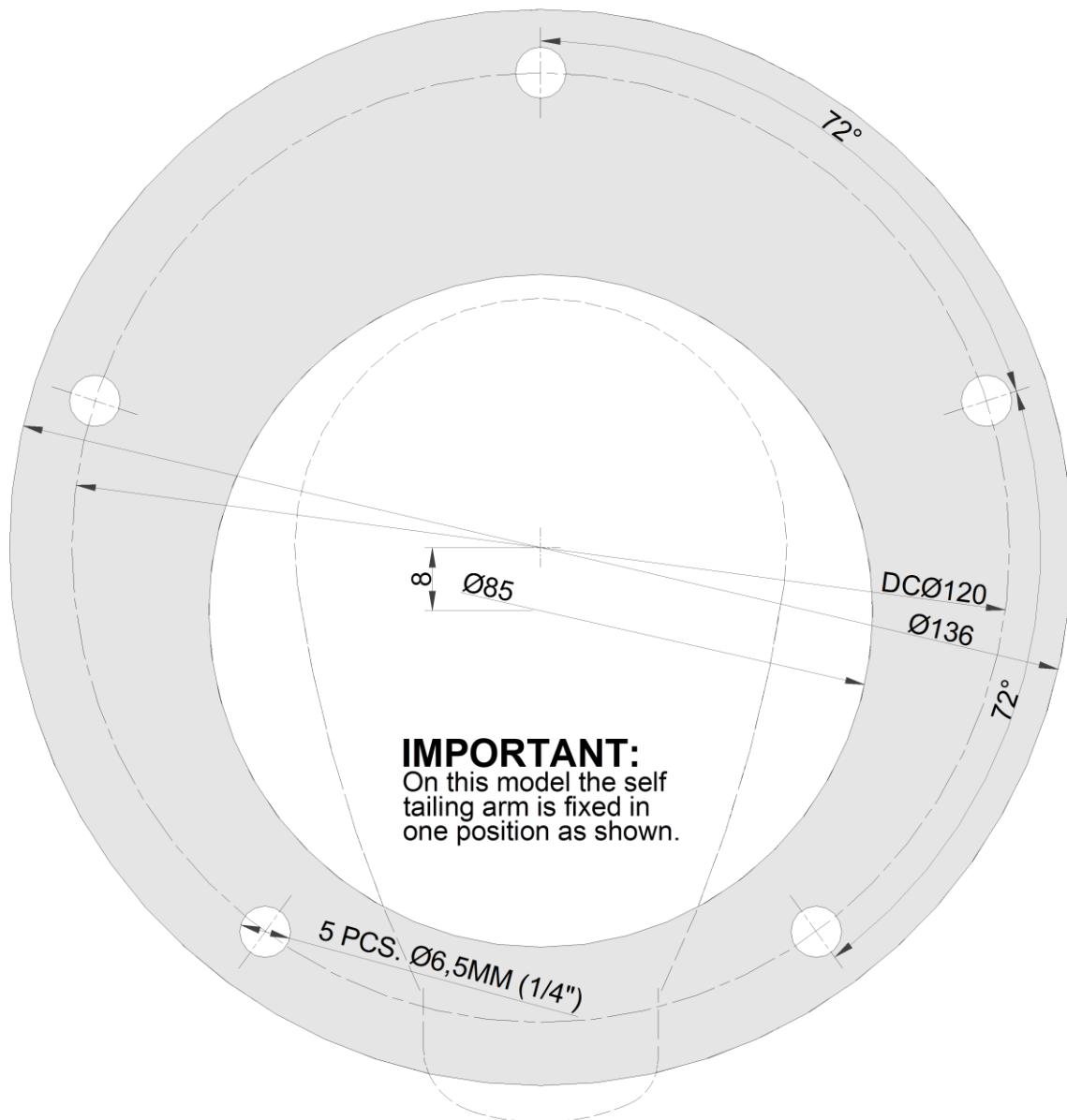

(Non-dimensional accuracy)



DRILLING TEMPLATE

40 STE SE

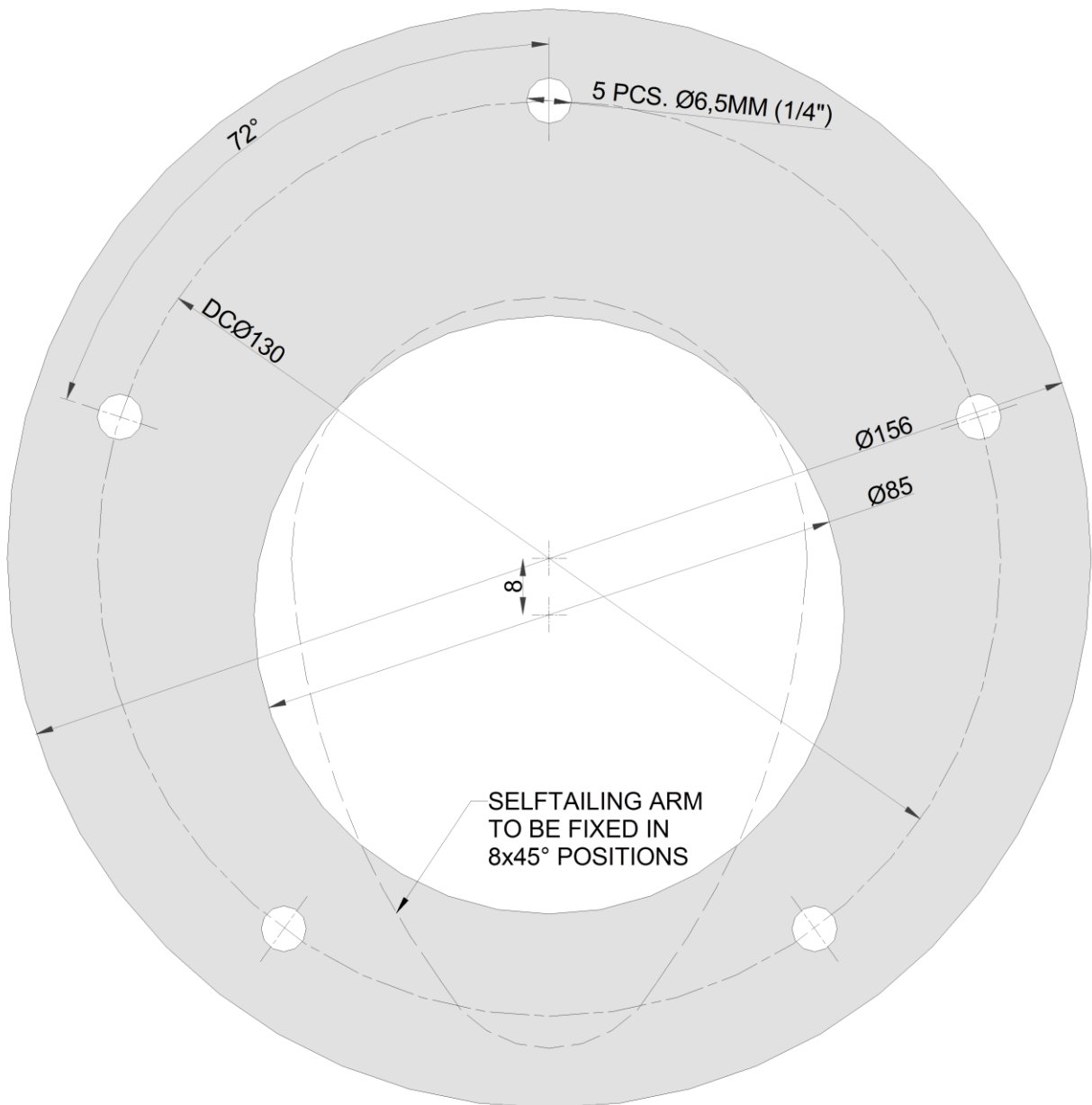

(Non-dimensional accuracy)

EXPLODED VIEW

28 + 40 STE SE

2+1 SPEED

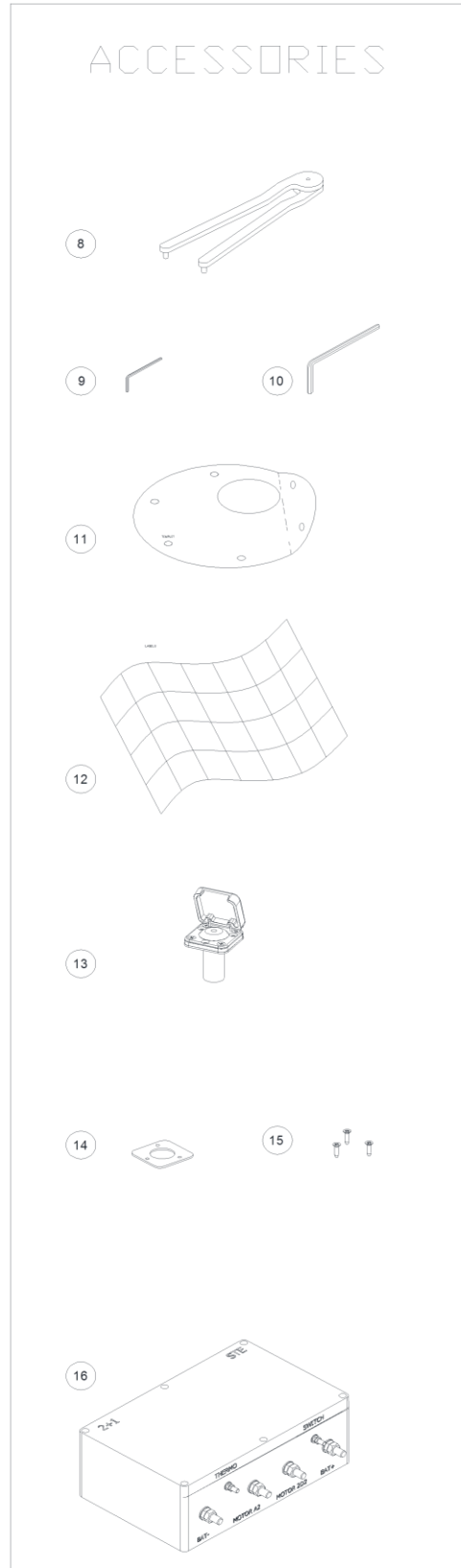
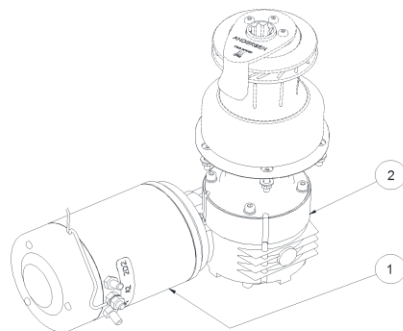
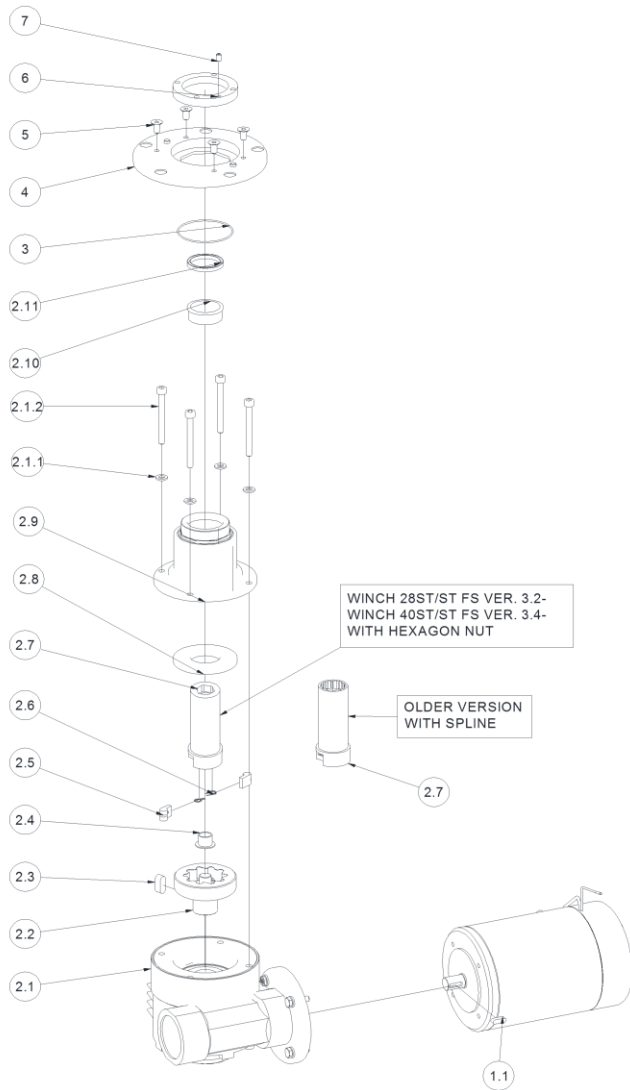

PARTS LIST

28 + 40 STE SE
2+1 SPEED

POS.	QTY.	DESCRIPTION	ART. NO.
	1	Gear complete 28STE TYPE2	777000
		Gear complete 40STE TYPE2	777020
1.	1	Motor CIMA 1000W 12V 28+40+46STE	777300
1.	1	Motor CIMA 1000W 24V 28+40+46STE	777310
1.1	1	Key	DIN6885-A-5X5X15
2.0	1	Gear Unit 28ST SE / 40 ST SE	776135
2.1	1	Gear i14 VF49	776200
2.1.1	4	Washer	DIN125-A4-Ø6
2.1.2	4	Screw	DIN912-A4-M6x55
2.2	1	Ratchet gear	776110
2.3	1	Key	DIN6885-A-8X7X20
2.4	1	Bushing	RD100439
2.5	2	Pawl	713200
2.6	2	Arm spring	713300
2.7	1	Drive shaft 28STE (<i>OLDER VERSION WITH SPLINE</i>)	822900
2.7	1	Drive shaft 40STE (<i>OLDER VERSION WITH SPLINE</i>)	824101
2.7	1	Drive shaft 28STE + 40STE	822901
2.8	1	Washer	775890
2.9	1	Drive shaft housing	776100
2.10	1	Bushing	RD100169
2.11	1	Sealing ring	823100
3.	2	O-ring	RD100074
4.	1	Deck plate 28STE	990400
4.	1	Deck plate 40STE	992500
5.	4	Screw	DIN7991-A4-M6x16
6.	1	Center Nut	584502
7.	1	Screw	DIN916-A4-M5x8
8.	1	Pin Spanner	RD738000
9.	1	Allen key	593000
10.	1	Allen key	592900
11.	1	Template 28STE	RD100327
11.	1	Template 40STE	RD100525
12.	1	Switch labels	RD100029
13.	1	Switch	RD581900
14.	1	Sealing	735050
15.	3	Screw	RD100025
16.	1	Control box 12V	990212
16.	1	Control box 24V	990224
	1	Manual 28+40STE SE 2+1 12+24V	710470

CONNECTING DIAGRAM 12V + 24V

28 + 40 STE SE

2+1 SPEED



WARNING:
Don't switch cables (+)
with cables (-).
Incorrect polarity will
permanently damage
the control box thus
invalidate warranty

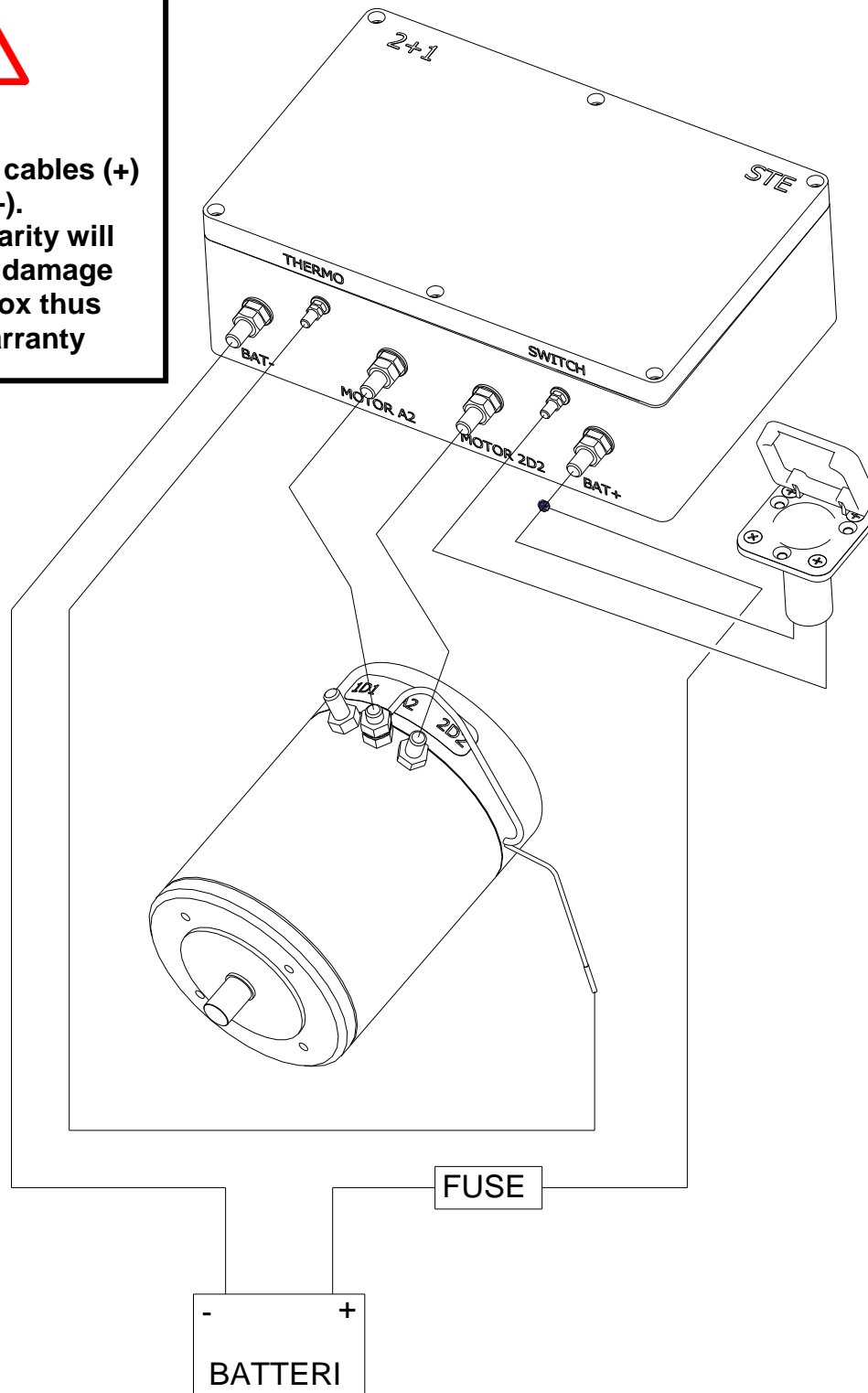

IMPORTANT: Do not use connection 1D1

REMARK: Fuse must be of a slow blow type

ANDERSEN
STAINLESS STEEL WINCHES

12

MINIMUM WIRE DIMENSIONS & FUSE SIZES

(Not for continuous service)

WINCH	WIRE LENGTH*	12V. DC			24V. DC		
		WIRE	FUSE	BAT. CAP.	WIRE	FUSE	BAT. CAP.
28 STE SE	0-3 m / 0-10 ft	35 mm ²	125 A	240 Ah	25mm ²	76 A	120Ah
	3-8 m / 10-27 ft	50 mm ²	160 A	240 Ah	25mm ²	100 A	120Ah
40 STE SE	0-3 m / 0-10 ft	35 mm ²	125 A	240 Ah	25mm ²	76 A	120Ah
	3-8 m / 10-27 ft	50 mm ²	160 A	240 Ah	25mm ²	100 A	120Ah
46 STE SE	0-3 m / 0-10 ft	50 mm ²	160 A	360 Ah	25mm ²	100 A	180Ah
	3-8 m / 10-27 ft	70 mm ²	200 A	360 Ah	35mm ²	125 A	180Ah
52 STE SE	0-3 m / 0-10 ft	50 mm ²	160 A	360 Ah	25mm ²	100 A	180Ah
	3-8 m / 10-27 ft	70 mm ²	200 A	360 Ah	35mm ²	125 A	180Ah

*) WIRE LENGTH is defined as the distance from battery to switch box + the distance from switch box to motor.

IMPORTANT: Fuse must be of a slow blow type.





WORLDWIDE DISTRIBUTION

(FOR UPDATED DISTRIBUTOR LIST, PLEASE SEE WWW.ANDERSENWINCHES.COM)

WARRANTY

Refer to our website www.ronstan.com/warranty for our warranty terms and conditions.

