

Manual CAPSTAN C3000

Version 1.0



Sail Handling by



Stainless Steel Winches
Stainless Steel Winches

Part no.: 710479
22-02-2010

CONGRATULATIONS

You have purchased an ANDERSEN high quality Capstan. This product is a result of many years of development and experience in producing winches for pleasure boats. This capstan gives you a high degree of functionality and many years of safe and easy mooring handling.

TILLYKKE

De har købt et ANDERSEN Capstan af høj kvalitet. Dette produkt er et resultat af mange års udviklingsarbejde samt erfaring indenfor produktion af spil til lystbåde. Med denne Capstan får De funktionalisme på højt plan med henblik på at yde Dem en behagelig samt sikker sejlads.

Sehr geehrter ANDERSEN kunde,

wir beglückwünschen Sie zu dem kauf einer ANDERSEN Capstan, ein Produkt höchster Qualität, daß ein Resultat jahrelanger Entwicklungsarbeit und Erfahrung in der Produktion von Winden für Segelboote ist. Die funktionalität dieser Capstan ermöglicht Ihnen viele Jahre lang eine handliche und sichere Segelführung.

FÉLICITATIONS

Vous venez d`acheter un Capstan ANDERSEN de grande qualité. Ce produit est le résultat de longues années d`expérience et de développement dans la production des capstans pour voilier. Ce winch vous apportera de nombreuses années de fonctionnement sécurisant, pour une voile facile.

Annette Andersen Lau
Managing Director

GENERAL INFORMATION

Due to the best choice of materials and high precision in manufacturing, we recommend, for normal use, only to dismantle, clean and lubricate the capstan once every second year. Under extensive use, such as racing, charter or blue water sailing, we recommend to lubricate the capstan once every year.

We strongly recommend always using ANDERSEN WINCH GREASE, when lubricating your capstan. ANDERSEN WINCH GREASE is a high quality silicone/Teflon® grease product. Most other types of grease, including “marine grease” are not suitable for lubrication of capstans. Non-suitable grease products can cause malfunction, which could result in fatal injuries for the user and others.

Pawl arm springs should be replaced every second year. Spare arm springs and other parts that may be required are included in the ANDERSEN Service Kit. Please refer to the service instruction for the Service Kit suitable for the specific capstan.

INSTALLATION

CAPSTAN C3000 ver. 1.0

Installing the capstan is easy, if you follow these instructions. The numbers in () refer to the position numbers in the parts list.

Tools required for the installation:

Allen key (5 mm.).

Allen key (10 mm.).

Drill Ø12,5mm.

6 pcs. M12 Socket head cap screws and corresponding nuts (length depending on deck thickness).

6 x large washers or backing plate.

Ring spanner to match nuts.

Bedding compound

1. Remove screws (1).
2. Remove the top disc (2) and drum (3).
3. Mark location of bolt holes and hole for gearunit (if there is a gearunit), using the template.
4. Loosen screws (6) and remove base consist of (4), (5), (7) and (9).
5. Remove complete capstan. Be sure that no dust comes into contact with the capstan while drilling.
6. Drill bolt holes ø12,5 mm and cut hole for gearunit, using template (10).
7. Apply a light coat of bedding compound, ensuring that each bolt hole is bedded. Keep drain grooves clear.
8. Fasten cover (8) into place using 6 pcs. M12 screws. Use large washers or a backing plate.
9. Assemble in reverse order.
10. Check that the capstan is functioning correctly:
The drum should operate smoothly, by turning the drum clockwise by hand.
The drum must not turn when trying to turn the drum anti clockwise.

INSTALLATION VIEW

CAPSTAN C3000 ver. 1.0

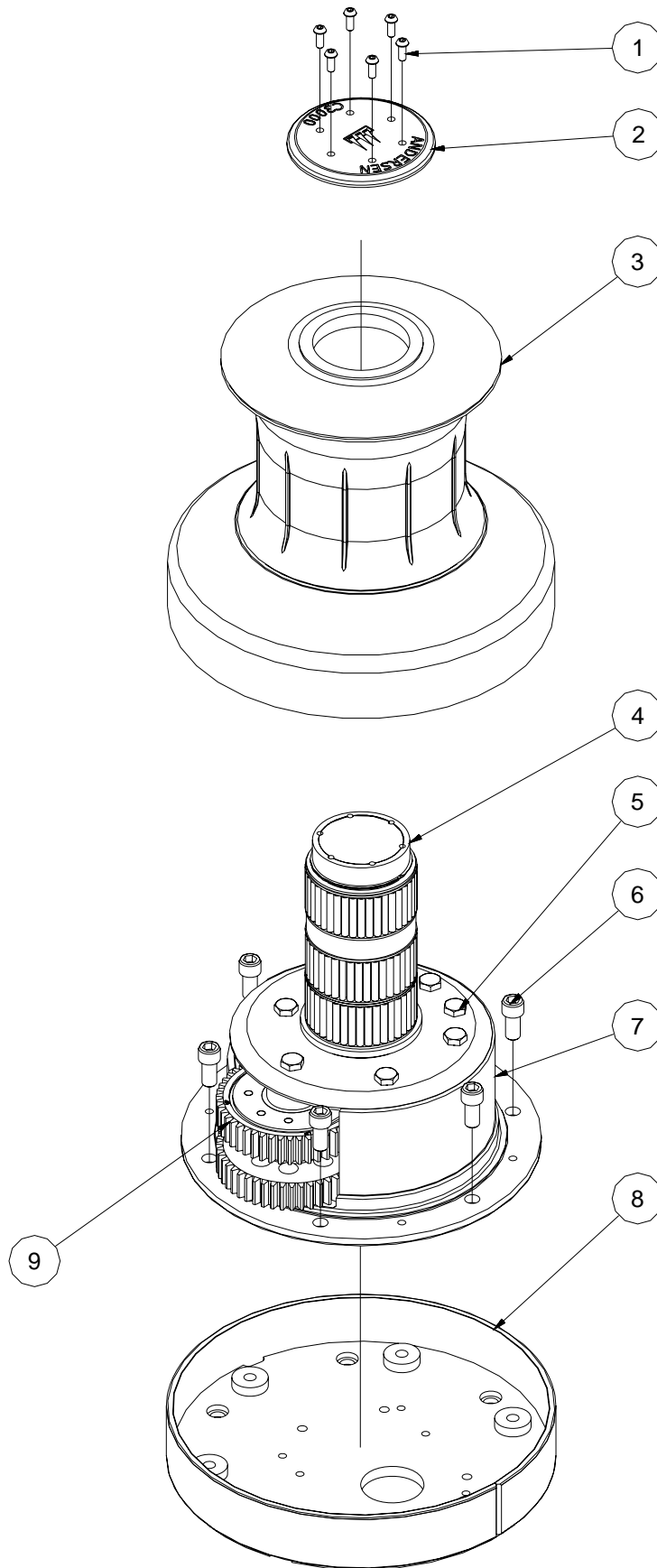

SERVICE INSTRUCTION

CAPSTAN C3000 ver. 1.0

Tools required for service:

Allen key (5 mm.).

Allen key (6 mm.).

Allen key (10 mm.).

Spanner (17 mm.).

Screwdriver (small).

ANDERSEN Winch grease.

1. Remove screws (1).
2. Remove the top disc (2) and drum (3).
3. Remove circlip 4.2, ring 4.3, roller bearing 4.4, distance ring 4.5. Bearing (4.6) and balls (4.7), are not removable.
4. Remove bolts (5) and upper base (4.1)
5. Remove ratchet gear (9) and dismantle it.
6. Clean the balls (4.7) and the bearing (4.6) above the balls with a small soft brush.
7. Clean all parts in benzine. Remember to clean the inside of the drum.
8. Assemble in reverse order. During assemble, lightly grease all gear teeth, drive shaft, shafts, balls, pawls, springs and composite bushings. Use a small, soft brush. Pawls may be lubricated with a very thin film of ANDERSEN WINCH GREASE. It is very important that pawls can move freely.

IMPORTANT: When assembling the capstan, check the function of each pawl by pushing the pawl against the spring. The pawls should smoothly and automatically return to their normal position, where the pawls engage with the teeth. If the pawls do not function correctly, clean and lightly lubricate the pawls and gears again and replace the springs where necessary.

Malfunctioning pawls may lead to unexpected failure of a loaded capstan resulting in material damage or fatal personal injury.

Service Kit No: 7 (part. no. 710007) contains spare parts for this Capstan.

For current World Wide Distributor list please see:
www.andersenwinches.com

EXPLODED VIEW

CAPSTAN C3000 ver. 1.0

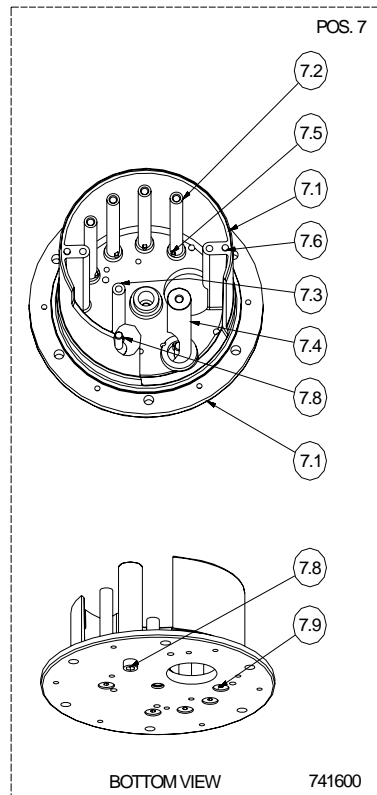
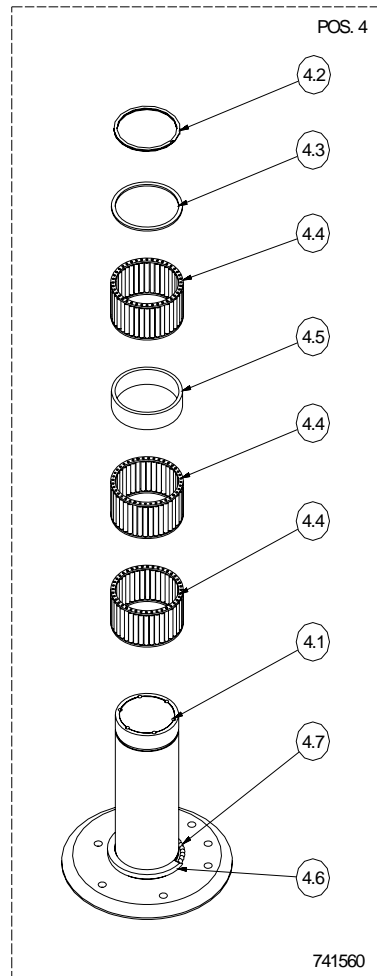
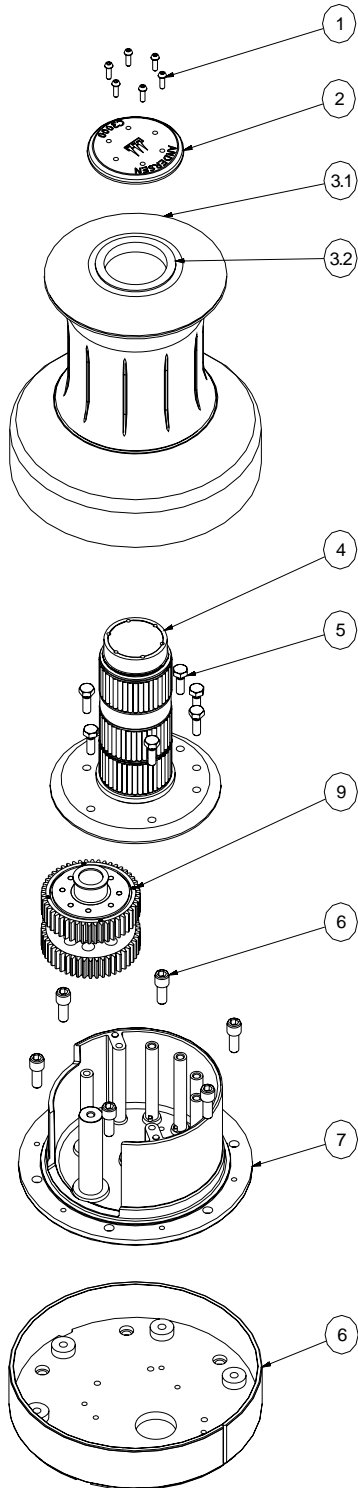
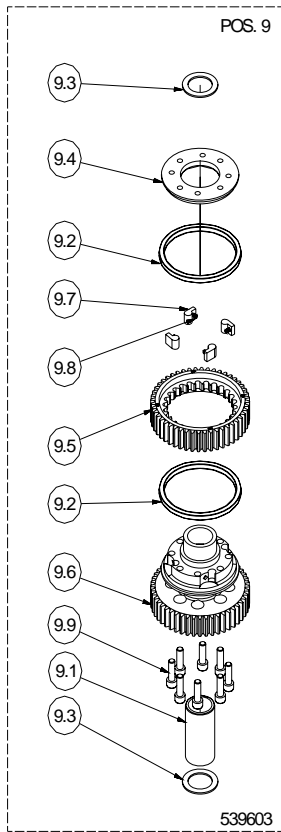

PARTS LIST

CAPSTAN C3000 ver. 1.0

POS.	QTY.	DESCRIPTION	ART. NO.
1	6	Screw	ISO7380-A4-M6x16
2	1	Disc	733550
3	1	Drum, Complete	741340
3.1	1	Drum	741350
3.2	1	Bearing	539250
4	1	Upper Base, Complete	741560
4.1	1	Upper Base	741550
4.2	1	Circlip	590400U
4.3	1	Ring	538300
4.4	3	Roller Bearing	539200
4.5	1	Distance Ring	538250
4.6	1	Bearing	539500
4.7	46	Ball	724902
5	8	Screw	DIN 933-A4-M10x25
6	6	Screw	DIN 912-A4-M12x25
7	1	Lower Base, Complete	741600
7.1	1	Lower Base	741601
7.2	4	Shaft	539400
7.3	1	Shaft for Gearwheel	537600
7.4	1	Shaft for Ratchetgear	537302
7.5	4	Pin	ISO2338-A4-5h8x10
7.6	2	Pin	DIN7-A1-8H8x16
7.7	1	Pin	DIN7-A1-5H8x14
7.8	1	Pin	DIN7-A1-5H8x5
7.9	1	Screw	DIN6912-A4-M12x25
7.10	5	Screw	DIN7991-A4-M10x25
8	1	Base Cover	751150
9	1	Ratchet Gear, Complete	539603
9.1	1	Bearing	532600
9.2	2	Bearing	534800
9.3	2	Bushing	983401
9.4	1	Ring	537201
9.5	1	Ratchet Gearwheel	537701
9.6	1	Gearwheel	542201
9.7	4	Pawl	712500
9.8	4	Spring	533500
9.9	8	Screw	DIN912-A4-M8X25
10	1	Template	RD100519
11	1	Manual	710479

LIMITED WARRANTY

- 1.1 ANDERSEN issue a three-year warranty on all their products covering manufacturing and material defects on condition that the products are used in normal fashion. The warranty shall apply for three years from the moment ANDERSEN sell the product concerned (to the first buyer).
- 1.2 Within the period of the warranty, and in accordance with the terms of the warranty, ANDERSEN undertake to replace or repair all defective components which have been used in normal fashion.
- 1.3 However, the warranty is subject to the limitations and exceptions outlined below.
2. **Conditions and limitations:**
 - 2.1 ANDERSEN's liability shall be limited to repair or replacement of components which are defective owing to manufacturing or material defects.
 - 2.2 ANDERSEN assume no other liability than this, not even liability for indirect losses caused by defect concerned, including operating losses, loss of profits, or damage caused to real property or moveable property occurring while the product concerned is in the possession of the Buyer.
 - 2.3 The Buyer alone shall bear the responsibility and risk involved as to whether the product is suitable for the application intended. ANDERSEN assumes no liability in this connection.
 - 2.4 ANDERSEN assume no liability for defects which occur due to use of their products for purposes for which they are not intended, or for defects which occur owing to incorrect installation, corrosion, ultraviolet degradation, lack of maintenance, or any alteration or repair of the product carried out incorrectly by the Buyer. Finally, ANDERSEN assumes no liability for normal wear and tear, or for depreciation of value.
 - 2.5 Nor do ANDERSEN assume any liability for service carried out by anyone other than authorised representatives of ANDERSEN, unless such service is carried out pursuant to guidelines laid down by ANDERSEN and in accordance with good craftsmanship.
 - 2.6 The buyer shall inform ANDERSEN in writing of any defects with no undue delay once defects have been registered. Products being dealt with under the warranty shall be returned to ANDERSEN for repair unless any other agreement has been reached in writing.
 - 2.7 ANDERSEN shall not cover costs incurred by the Buyer in connection with the transport or wages involved in a warranty case. Such costs shall be met by the Buyer in full.
3. **Exceptions:**
 - 3.1 The warranty is only valid for one year in respect of components bought for the products concerned, such as electric motors, electric equipment, hydraulic pumps, motors and valves.
 - 3.2 ANDERSEN assume no liability for consequential damage of ships, equipment, property or people by defects in ANDERSEN's products.
 - 3.3 The company's products are subject to continuous development, and consequently ANDERSEN reserve the right to change designs and specifications without prior notice.

WORLDWIDE DISTRIBUTION

ANDERSEN Argentina

Argen Mast & Systems s.r.l.
Av. Tiscomia 963
(1642) San Isidro
Buenos Aires
Tel.: 11 4742 44 62
Fax: 11 4742 44 62
E-mail: info@argenmast.com.ar
Web: www.argenmast.com.ar

ANDERSEN Australia

Allyacht Spars Australia 1853 Lytton Rd.,
Lytton
Queensland
Australia 4178
Tel.: 07 3893 2233
Fax: 07 3893 2478
E-mail: info@allyachtspars.com.au
Web: www.allyachtspars.com.au

ANDERSEN Austria

Robert Lindemann KG
Wendenstrasse 455
D-20537 Hamburg
Tel.: 040 21 11 970
Fax: 040 21 11 97 30
E-mail: info@lindemann-kg.de
Web: www.lindemann-kg.de

ANDERSEN Belgium

Jupiter Handelsmijl. BVBA
Helststraat 51/12
B-2630 Aartselaar
Tel.: 03 457 43 81
Fax: 03 457 68 21
E-mail: info@jachtenjupiter.com
Web: www.jachtenjupiter.com

ANDERSEN Canada

Rekord Marine Enterprises Ltd
8194 Ontario Street
Vancouver, B.C., V5X 3E3
Tel.: 604 325 5233
Fax: 604 325 0326
Toll free fax: 1-800-663-6424
E-mail: jeremy@rekord-arine.com
Web: www.rekord-marine.com

ANDERSEN Croatia

Navela
Castropola 54
HR-52100 Pula
Croatia
Tel.: 052 214 542
Fax: 052 213 558
E-mail: navela@pu.t-com.hr
Web: www.navela.hr

ANDERSEN Czech Republic

Nereide Yachting Ltd.
Vybiralova 972/70
CZ-19800 Prague 9
Tel: 605 25 98 82
Fax: 257 94 17 84
E-mail: office@nereide-yachting.com
Web: www.nereide-yachting.com

ANDERSEN Denmark

WATSKI A/S
Savsvinget 4
DK-2970 Hørsholm
Tel.: 45 76 40 11
Fax: 45 76 40 12
E-mail: kontaktdk@watski.com
Web: www.watski.dk

ANDERSEN Finland

Ky Jotiko-Marine Kb
Unioninkatu 45
SF-00170 Helsinki
Tel.: 103 870 500
Fax: 103 870 509
E-mail: info@jotiko-marine.com
Web: www.jotiko-marine.com

ANDERSEN France

Greement Import – Head office:
13 rue du Chêne Lassé
Z.I. BP 284
44803 Saint Herblain
Tel.: 02 28 03 01 01
Fax: 02 28 03 19 91
E-mail: contact@greementimport.fr
Web: www.greementimport.fr

ANDERSEN Germany

Herman Gotthardt GmbH
Leunastrasse 50
D-22761 Hamburg
Tel.: 040 851 50 50
Fax: 040 850 91 33
E-mail: info@gotthardt-yacht.de
Web: www.gotthardt-yacht.de

ANDERSEN Great Britain

IMP
Jarman Way
Royston
Hertfordshire SG8 5HW
Tel.: 01 763 241 300
Fax: 01 763 241 770
E-mail: sales@improducts.co.uk
Web: www.improducts.co.uk

ANDERSEN Greece

Meltemi Yachting Ltd.
4, Metamorfoseos st Alimos
GR-17455 Athens
Tel.: 210 9849983
Fax: 210 9844356
E-mail: info@meltemi-yachting.gr
Web: www.meltemi-yachting.gr

ANDERSEN Hong Kong

Storm Force Marine Ltd
1204 Dominion Centre
43-53 Queens Road East
Wanchai, Hong Kong
Tel.: +852 2866 0114
Fax: +852 2866 9260
E-mail: simon@stormforcemarine.com
Web: www.stormforcemarine.com

ANDERSEN Hungary

Marina Yacht Sport
Bécsi út 118. H-1037 Budapest
Tel.: 1 322 86 55
Fax: 1 322 9834
E-mail: iroda@marina.hu
Web: www.marina.hu

ANDERSEN Italy

TOMASONI TOPSAIL S.p.A.
Via E.Toti 55
16035 Rapallo (GE)
Tel.: 0185 2001
Fax: 0185 263 160
E-mail: vela@tomasoni.com
Web: www.tomasoni.com/tecnico

ANDERSEN Netherlands

Nautec Engineering B.V.
Muyterweg 17
6075 AM Herkenbosch
Tel.: 0475 537760
Fax: 0475 537759
E-mail: info@nautec.nl
Web: www.nautec.nl

ANDERSEN New Zealand

Nordic Marketing Ltd.
P.O. Box 100669
NSPS, North Shore City
Tel.: 09 488 7605
Fax: 09 488 7608
E-mail: nordic@xtra.co.nz
Web: www.nordic.co.nz

ANDERSEN Norway

Skaane Marine AS
Bromsveien 5
N-3183 Horten
Tel.: 33 02 05 90
Fax: 33 02 05 99
E-mail: post@skaane.no
Web: www.skaane.no

ANDERSEN Poland

Sail Service
ul.Sienna 45
80-605 Gdansk
Tel.: 58 3 222 822
Fax: 58 3 222 802
E-mail: office@sailservice.com.pl
Web: www.sailservice.com.pl

ANDERSEN Portugal

Just Boats
Lote 32, Urb. Goldra
8100-263 Loulé
Tel.: 289 994 204
Fax: 289 994 485
E-mail: info@just-boats.net
Web: www.just-boats.net

ANDERSEN Russia

Yachtglanz - Marine Equipment
Portugiesischer Weg 14
D-44143 Dortmund
Tel.: +49 (0)231 996 48 35
Fax: +49 (0)231 530 74 47
E-mail: info@yachtglanz.com
Web: www.yachtglanz.com

ANDERSEN Singapore

Alquest Marketing
66, Tannery Lane
#02-06B Sindo Building
Singapore 347805
Tel.: 6749 9359
Fax: 6749 9360
E-mail: jason@alquest.com.sg
Web: www.alquest.com

ANDERSEN Slovenia

Tramontana
Tesovnikova 88
1000 Ljubljana
Tel.: 01 568 37 32
Fax: 01 565 48 88
E-mail: info@tramontana-net.si
Web: www.tramontana-net.si

ANDERSEN South Africa

Manex & Power Marine
5 Industry Street
P.O. Box 173
Paarden Eiland 7420 Cape Town
Tel.: 021 511 7292
Fax: 021 510 1487
E-mail: manex@manex.co.za
Web: www.manex.co.za

ANDERSEN Spain/Mallorca

Yacht Riggers Mallorca, s.l.
Passeig República Argentina, 34 baixos
E-07200 FELANITX (Mallorca)
Tel.: 971 58 41 30
Fax: 971 58 41 31
E-mail: info@yachtriggers.com
Web: www.yachtriggers.com

ANDERSEN Spain/Barcelona

Pertrechos Nauticos S.L.
Buscarons, 6 bj. local 2
08022 Barcelona
Tel.: 93 418 66 32
Fax: 93 418 56 48
info@pertrechosnauticos.com
www.pertrechosnauticos.com

ANDERSEN Sweden

Navimo Nordic AB
Lundenvägen 2
S-473 31 Henån
Tel.: 0304 360 60
Fax: 0304 307 43
E-mail: info@navimo.se
Web: www.navimo.se

ANDERSEN Switzerland

Robert Lindemann KG
Wendenstrasse 455
D-20537 Hamburg
Tel.: 040 21 11 97 0
Fax: 040 21 11 97 30
E-mail: info@lindemann-kg.de
Web: www.lindemann-kg.de

ANDERSEN Trinidad & Tobago

Soca Sails
Crewsinn Marina, Chaguaramas
P.O. Box 608
Trinidad, West Indies
Tel.: 868 634-4178
Fax: 868 634-1044
E-mail: info@socasails.com
Web: www.socasails.com

ANDERSEN Turkey

Yenisehir Mahallesi
Bahar Sokak No: 12/9 Blok A2-6
34912 Pendik, Istanbul
Tel.: 533 399 99 77
E-mail: turkey@andersenwinches.com
Web: www.andersenwinches.com

ANDERSEN Ukraine

Yachtglanz - Marine Equipment
Portugiesischer Weg 14
D-44143 Dortmund
Tel.: +49 (0)231 996 48 35
Fax: +49 (0)231 530 74 47
E-mail: info@yachtglanz.com
Web: http://www.yachtglanz.com/

ANDERSEN U.S.A.

Navimo USA, Inc.
7455 16th street E
Suite 107
Sarasota
FL 34243
U.S.A.
Toll-free tel. 866.383.1888
Tel.: 941.360.1888
Toll-free fax 866.214.1400
Fax: 941.360.1648
E-mail: info@navimousa.com
Web: www.navimousa.com

Andersen Winches, Jaergervaenget 36, DK-7100 Vejle, Denmark – tel. +45 76427777 – fax +45 76427788
e-mail: info@andersenwinches.com web: www.andersenwinches.com