



# INSTALLATION MANUAL

## Motorized Reefing-Furling Systems



NOTE TO RIGGERS OR  
PERSONS IN CHARGE  
OF INSTALLATION  
OF THE SYSTEM

Please give this manual to the owner of the boat, and ask him (her) to read it carefully before using the system. This manual should always be kept on board for future reference.

### Electric models

**NDE 42**     12V  
                           24V

**NDE 52**

### Hydraulic models

**NDH 42**

**NDH 52**

Serial number:

Ref. 51131c



# MOTORIZED PROFURL SYSTEMS

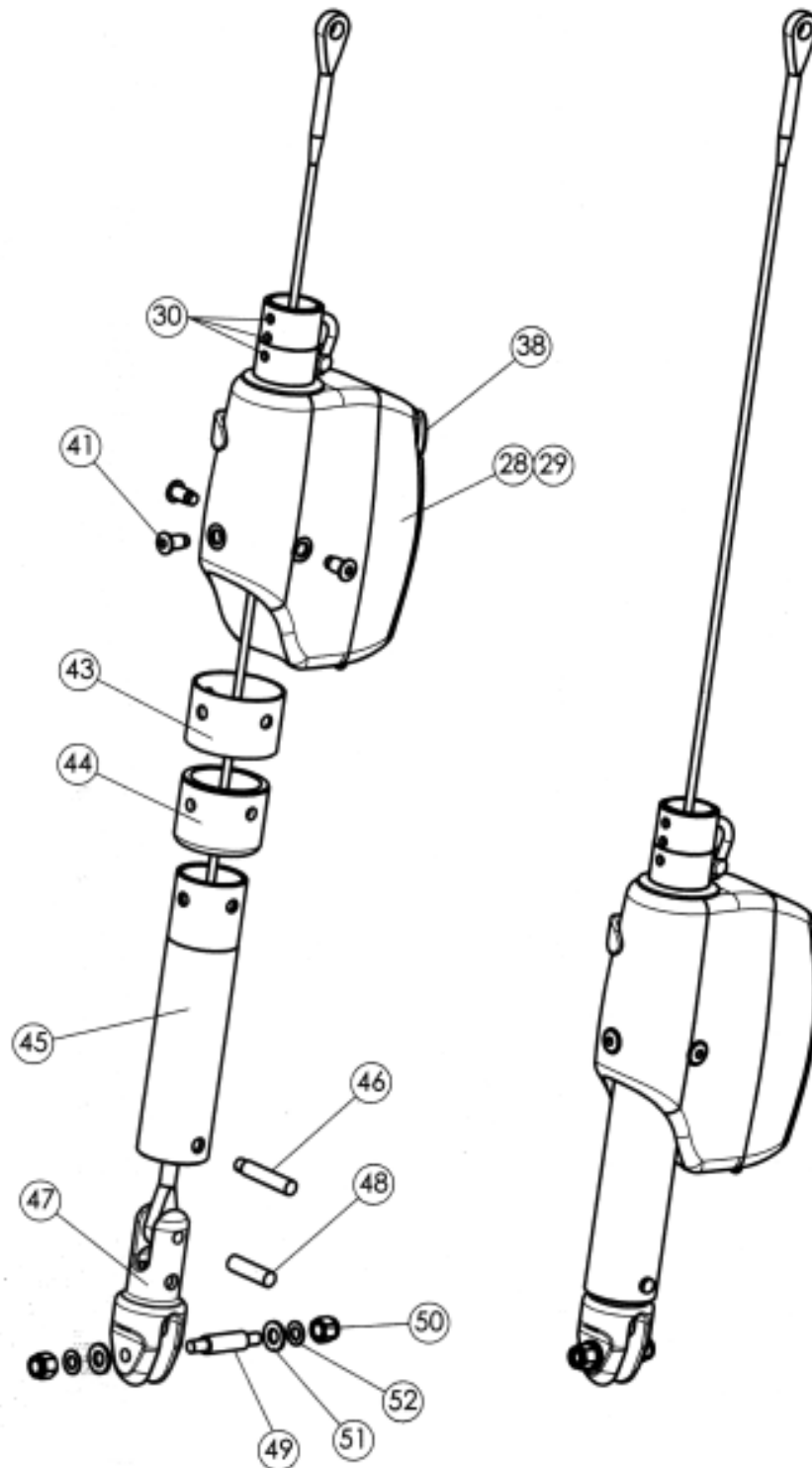

# CONTENTS

## Pages

4	Preliminary cautions
5	Fitting the mechanical parts :
5-6	• Adaptation of the original forestay
7	• Fitting height of the gear motor above deck
8	• Fitting the gear motor
9	• Cutting extrusions to length
10	Connecting an electric system
11	Connecting a hydraulic system
12	Finishing fitting
12	Use of the manual override
13	Spare parts :
13	• NDE C 42
14	• NDE R 42
15	• NDE 52
16	• NDH C 42
17	• NDH R 42
18	• NDH 52
19	Dimensions of models 42
20	Dimensions of models 52

## RECEIPT OF GOODS

All goods must be checked on delivery and the purchaser should claim from the carrier within seven days in the event of loss or damage.



### CAUTION !

1- - Before connecting the system to the electric or hydraulic circuit, please try first to furl and unfurl the sail manually with the handle supplied.

2- The PROFURL motorized reefing-furling systems are extremely powerful. Please carefully follow the safety recommendations below :



• Never leave a handle inserted in the socket used for manual override (located at rear end of gear motor). Fit the cap over the socket as soon when the handle removed.



• Disconnect the control box and electrical circuits when the system is not in use, especially when children are on board



• When furling check that the jib sheets are running free and are not jammed.



• Keep clear from the system during operation.

### MEANING OF SYMBOLS USED IN THIS MANUAL :



: may cause physical injury if not strictly followed



: may cause material damage if not strictly followed

## FITTING THE MECHANICAL PARTS

The PROFURL motorized headsail reefing-furling systems are designed to be fitted over the existing forestay.

The following components are identical to a PROFURL manual system:

- extrusions and connectors. The gear motor replaces the drum mechanism found on a manual PROFURL system. Please check assemblies of these components in the standard drum Installation Manual, pages 18 and 19.
- halyard swivel (pages 20 and 25) and Wrapstop (page 17)

### ADAPTATION OF THE ORIGINAL FORESTAY

- The toggle (47) - please see page 2 - supplied must be attached directly onto the stemhead chainplate and to the bottom eye of the forestay. No other fitting should be inserted between the toggle and the chainplate.

Accurately measure the overall length pin to pin of your forestay.

- If an eye and adjustment plates are fitted please mark the position of the eye between the plates.
- If a turnbuckle is fitted, please mark the adjustment position of the turnbuckle: this will maintain your existing mast rake and forestay tension.

#### I - ORIGINAL FORESTAY WITH EYE AND ADJUSTMENT PLATES

##### ADAPTATION OF THE FORESTAY

- The adjustment plates should be completely removed
- The toggle supplied with the system should replace the adjustment plates.

- Should the forestay be too short: fit the adjustment plates or a standard toggle at the top of the stay, or fit a new forestay.
- Should the forestay be too long it should be shortened to the correct length and a new eye swaged at the bottom of the stay.

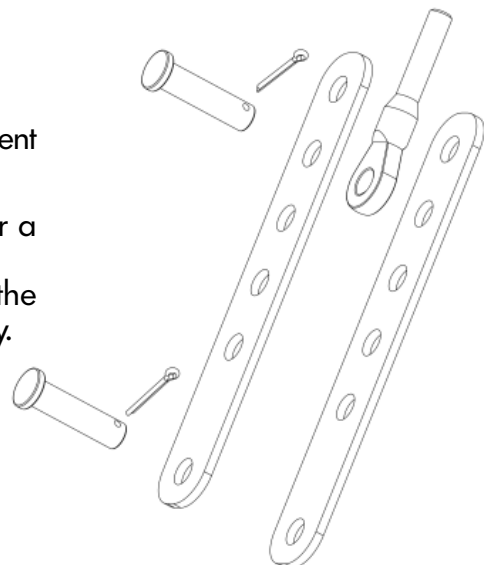

## II - ORIGINAL FORESTAY WITH A TURNBUCKLE

### MODIFICATION OF THE FORESTAY

You should check, modify or change your forestay to have an eye at the bottom of your turnbuckle.

Fit the PROFURL toggle (47) supplied between the bottom eye of the forestay and the toggle, fit the pin (48) supplied, without using any other part in this assembly.

Check on your turnbuckle that dimensions M and diameter N are smaller than the ones shown on headboard 1.

### Headboard 1

Models	Ø N maxi	M maxi	
		Without turnbuckle cylinder	With turnbuckle cylinder
NDE/NDH 42 Stay diam. maxi 12,7mm (1/2")	40 mm 1 9/16"	383 mm 1' 3 1/16"	723 mm 2' 4 7/16"
NDE/NDH 52 Stay diam. maxi 16 mm (5/8")	50 mm 2"	—	730 mm 2' 4 3/4"

- Should the forestay be too short: add a toggle at the top of the stay, or change for a new stay.
- Should the forestay be too long: shorten the wire and have a new turnbuckle with an eye terminal swaged at the bottom end of the stay.

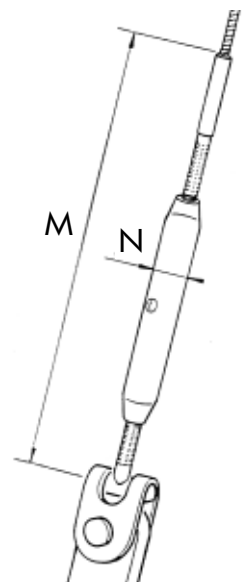
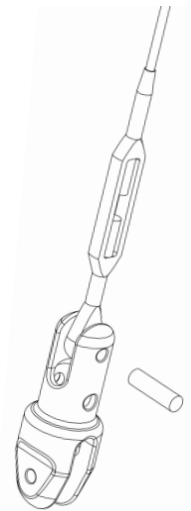

## III - ORIGINAL FORESTAY WITH AN EYE JAW TOGGLE

### ADAPTATION OF THE STAY

You should remove the captive pin to have an eye terminal. The PROFURL toggle supplied should be fitted between the eye and the chainplate, with no other fitting inserted in between.

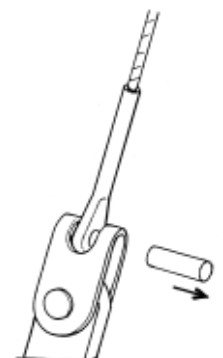

## IV - FITTING ON A ROD STAY

Please contact PROFURL.

## ADJUSTMENT OF THE HEIGHT OF THE GEAR MOTOR ABOVE DECK

1. The NDE / NDH motorized PROFURL systems allow you to choose the height of the gear motor above deck. The maximum allowed dimensions of the lower terminal may also determine the minimum height of the gear motor above deck. Please refer to headboard 1 for dimensions.

2. Measure the forestay terminal as per headboard 1 to check whether adjustment is possible, and until which amount. Please refer to drawing for minimum allowed length (L) of the tube.

3. Fitting the gear motor low to deck is achieved by shortening the stainless steel tube (45) located between the gear motor (28 or 29) and the toggle (47).

**THE TUBE SHOULD BE SHORTENED ONLY AT ITS LOWER END.**

It is preferable the tube is shortened by machining in a lathe.

4. Having shortened the tube drill :

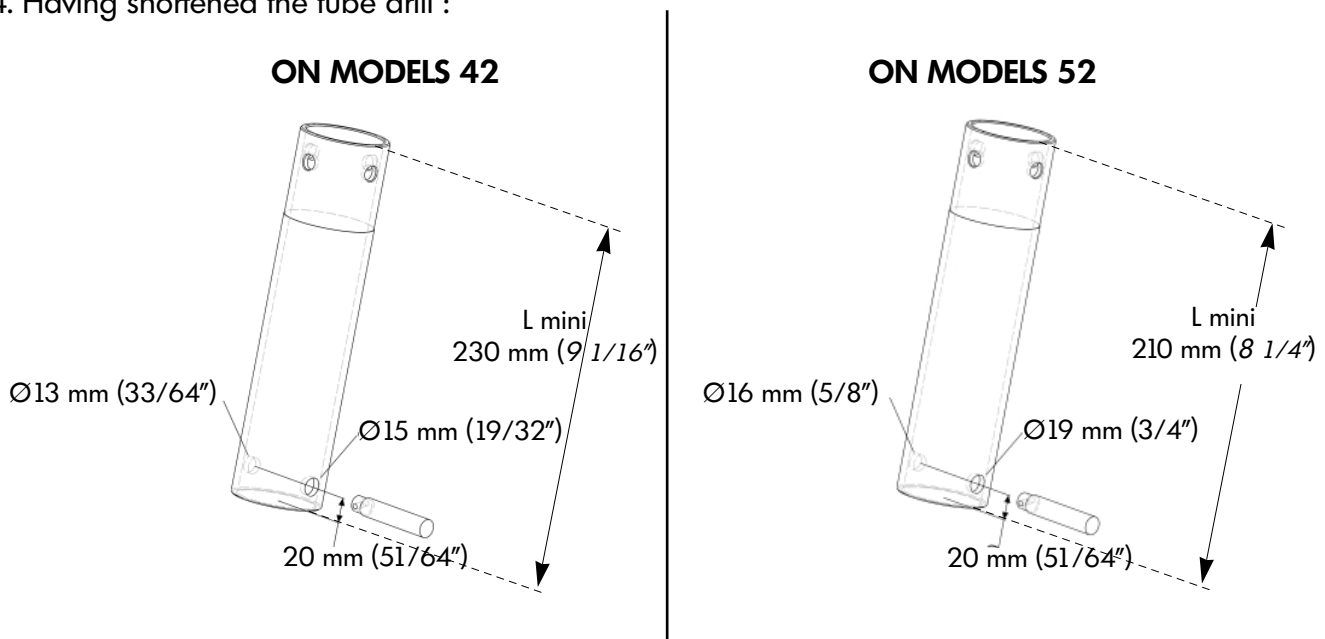

a  $13 \text{ mm}^{+0}_{-1}$  ( $33/64''^{+0}_{-3/64''}$ ) hole on one side,  
a  $15 \text{ mm}^{+0}_{-1}$  ( $19/32''^{+0}_{-3/64''}$ ) on the opposite side  
at the same distance -  $20 \text{ mm}^{+0}_{-1}$  ( $51/64''^{+0}_{-3/64''}$ ) - from the bottom edge as the original holes.

a  $16 \text{ mm}^{+0}_{-1}$  ( $5/8''^{+0}_{-3/64''}$ ) hole on one side,  
a  $19 \text{ mm}^{+0}_{-1}$  ( $3/4''^{+0}_{-3/64''}$ ) on the opposite side

5. If the tube has been shortened it is strongly recommended that it is electro and hand polished. This will reduce discoloration and corrosion of the tube.

The gear motor should be temporarily fitted at the bottom end of the stay. This will allow you to :

- check that dimensions of the different components (stay, toggle, chainplate, turnbuckle, clevis pins, etc...) match together
- check that raising or lowering the anchor will not damage the system.
- accurately calculate the length of extrusions (please refer to page 9).

## FITTING THE GEAR MOTOR

1 - For models 42 only, if the system has been delivered with a turnbuckle cylinder (52) - optional "I" version:

- remove the shape adapter \* (32) from the gear motor,
- fit it at the top of the turnbuckle cylinder (52), align the 3 holes in the shape adapter with the 3 corresponding threaded holes in the cylinder.
- fit the turnbuckle cylinder (52) at the top end of the gear motor, and screws (54).  
*\* The inside shape of the shape adapter should match the outside shape of the extrusions (round C 42, or foiled R 42).*

2 - Depending on boat's design the stem head chainplate may have been constructed in either athwart-ships or longitudinal direction. The stainless steel tube (45) should be fitted into the gear motor in the correct position in order to ensure that the handle socket (38) in the gear motor is facing backwards.

3 - Slide up the gear motor over the bottom of the stay until the bottom forestay terminal is easily accessible.

4 - Slide up over the bottom end of the stay in this order :

- The stainless steel ring (44) fitted over the anti corrosion bushing (43)
- The stainless steel tube (45)

5 - Take the forestay bottom terminal through and out of the bottom end of the stainless steel tube, and fit the bottom eye onto the upper hole of the toggle (47). Retain the pin (48) in the hole of the toggle (45) with adhesive tape.

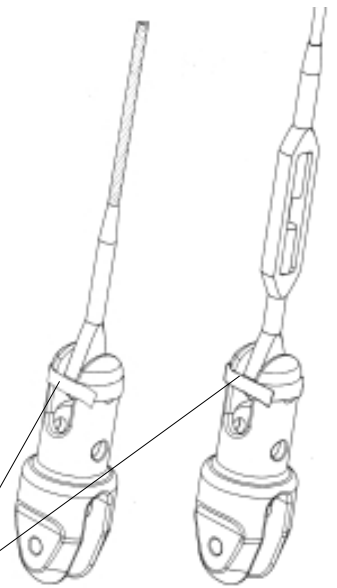

6 - Keep the gear motor raised (with a halyard if the system is fitted on a standing stay).

7 - Fit the toggle (47) over the chainplate with the threaded clevis pin (49) supplied, fit the washers (51) and the locknuts (50).

8 - Adjust tension of turnbuckle (if fitted).



Properly secure the turnbuckle to ensure that it will NOT unwind when operating the system.

9 - Lower the stainless steel tube (45) over the toggle, and fit the clevis pin (48) supplied (the one with a head) to connect the stainless steel tube (45) onto the lower hole of the toggle (47).

10 - Lower the gear motor over the stainless steel tube (45) and fit the 3 screws (41) to attach the gear motor onto the stainless steel tube.

11 - During final assembly of the extrusions, slide them vertically into the gear motor (or turnbuckle cylinder if any) so that the black mark on the lower extrusion is level with the top of the shape adapter (32). Fit the 3 set screws (30) to attach the bottom end of extrusions.



### CAUTION!

When adjusting your turnbuckle more open, please do not unwind and extend the turnbuckle longer than the maximum allowed length. Remind in case the stainless steel tube has been shortened, its dimension will be reduced accordingly. Please refer to headboard 1.



## CUTTING EXTRUSIONS TO LENGTH

Temporarily fit the gear motor onto the stay, as per steps 1 to 10 of previous page.  
Please refer to "L" on drawings.

Please measure "L":

- Without turnbuckle cylinder: between the upper edge of rotating shaft...
- With turnbuckle cylinder: between the upper edge of the turnbuckle cylinder...
- ... and the lower edge of the upper terminal, (where the wire disappears inside the swage terminal).

### Headboard 2

Models	The total length "G" of extrusions will be:
NDE/NDH 42	$G = L + 25 \text{ mm (1")}$
NDE/NDH 52	$G = L + 50 \text{ mm (2")}$

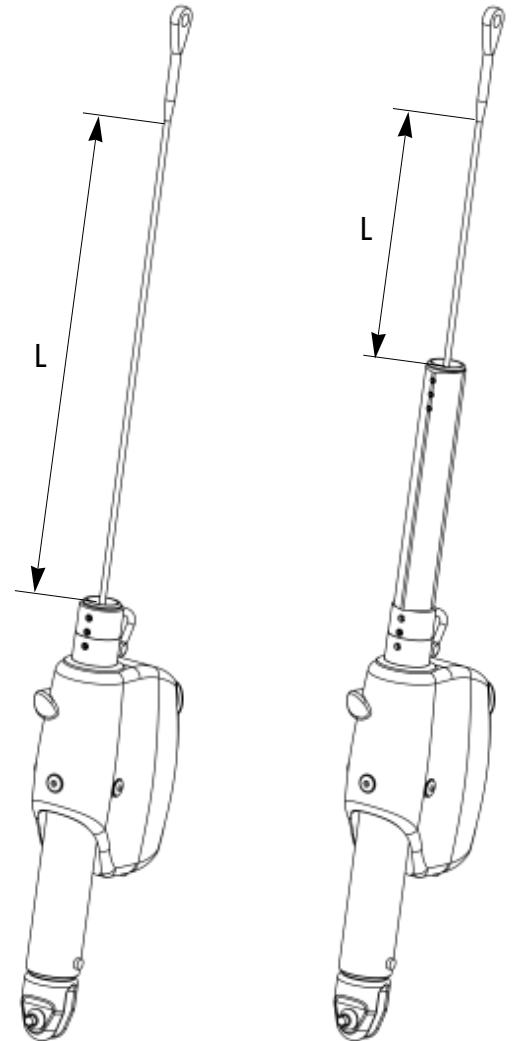

Every extrusion being 2 meter (6' 6 3/4") long, cut one extrusion to obtain a total length as "G". The cut end will be located at the top end of the extrusions.

Caution: the lower (feeder) extrusion (22) should not be cut.

Fitting the extrusions together is described in the Installation Manual pages 18 and 19.

# WIRING OF ELECTRIC SYSTEMS (NDE series)

Model	Power of motor		Outside diameter of the electrical wires		Minimal power supply wires section	
	12V	24V	12V (supplied)	24V	12V	24V
NDE 42	700 W	800 W	8.5 mm (11/32")	5 mm (3/16")	25 sq mm	16 sq mm
NDE 52	700 W	800 W	8.5 mm (11/32")	5 mm (3/16")	25 sq mm	16 sq mm

The two 5 Meter / 15 Ft electrical cables supplied are pre-wired in factory on the electric drive motor. The end of the two cables must be connected onto a relay box (PROFURL option). It allows the rotation of the motor to be reversed for furling/unfurling.

The relay box should be fitted inside the boat in a dry area.

A control box should be connected by cable to the relay box, to allow operating the system (normally from the cockpit).

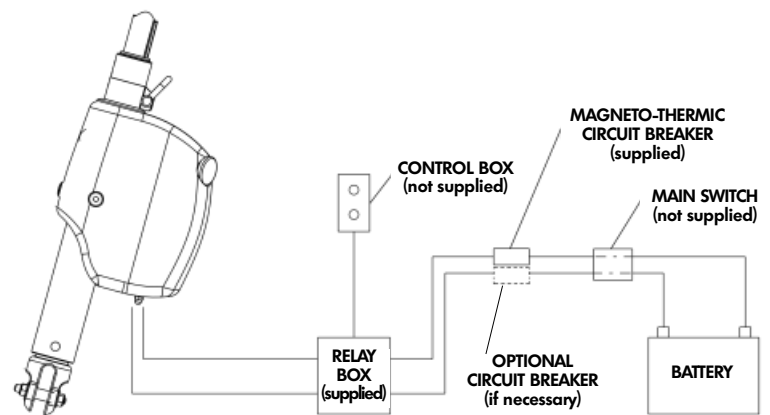

The electrical circuit has to be protected with the special circuit breaker supplied with the system, fitted as shown on drawing.

In case the boat has a metal hull, or is being used for commercial sailing in some countries, the circuit breaker should be specified as bi-polar, and ordered as an option at PROFURL.



CAUTION

The gear motor has been opened. Without the special tools and knowledge of the procedure to be followed, any attempt to open the gear motor without prior

Any attempt to open the gear motor without prior



PLEASE MAKE SURE THE ANCHOR CHAIN OR ANY OTHER LINE WILL NOT BE IN CONTACT WITH THE WIRES. Extra protection over the wires running above

# CONNECTING A HYDRAULIC SYSTEM (NDH series)

Models	Max operating pressure	Max rotation speed	Flow at max speed
NDH 42	100 Bars/1470 Psi	30 Rpm	15 L/mn 3.96 US Gal/min
NDH 52	140 Bars/2058 Psi	30 Rpm	15 L/mn 3.96 US Gal/min

- OIL
  - As per ISO 6073 HL
  - Viscosity 10 to 30 cst
- MAXIMUM OPERATION TEMPERATURES
  - minus 10°C to + 75°C with standard oil
  - minus 35°C to + 75°C with special oil
- HYDRAULIC PLUMBING CONNECTION
  - Requires two feeding hoses finished by female 7/16" JIC terminal
  - No drain

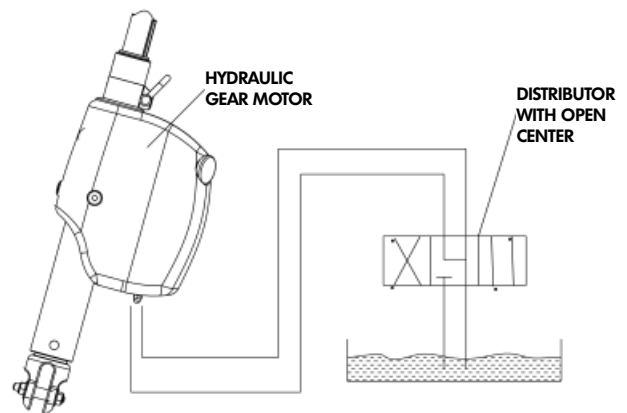

The connection onto the hydraulic gear motor should be achieved by flexible hoses above deck, being connected on through-deck fittings, and rigid tubing inside the boat.

- HYDRAULIC POWER PACKS
 

The PROFURL NDH 42 and NDH 52 are designed to be connected to the most common power packs. The output to feed the system should be adjusted to match the values as shown in the above headboard:

  - 100 bars / 1470 Psi for models NDH 42
  - 140 bars / 2058 Psi for models NDH 52

Should the power pack produce higher values than above, please use a limiter on the output feeding the system.

ION!

watertight tested in factory.  
open the gear motor, the unit may be permanently damaged.

written consent of PROFURL will void the warranty.

CHAFE ON THE ELECTRICAL WIRES OR HYDRAULIC HOSES ABOVE DECK.  
The deck is strongly recommended in any case.

## FINISHING THE INSTALLATION

### HOISTING THE SAIL

Please refer to standard drum Installation Manual page 24

### ADJUSTMENT OF THE HALYARD SWIVEL

Please refer to standard drum Installation Manual page 25

### FITTING AND ADJUSTING THE WRAPSTOP

Please refer to standard drum Installation Manual page 17

## USING THE SYSTEM FOR THE FIRST TIME

WHEN USING THE SYSTEM FOR THE FIRST TIME, PLEASE FURL AND UNFURL THE SAIL MANUALLY ONE TIME WITH THE HANDLE SUPPLIED TO CHECK THAT ALL ADJUSTMENTS (sail's luff length, position of halyard swivel, Wrapstop) ARE CORRECT.

## USING THE SYSTEM MANUALLY

If the electrical power supply to the system fails, a handle supplied with the system is to operate the system manually: it should be inserted into the socket located at the rear side of the gear motor. Please unscrew the cap (38) before inserting the handle into the socket.



### REMINDER !

- Disconnect the electrical power supply of the system before inserting the handle into the socket.
- Remove the handle from the socket and replace the cap as soon as the handle is not in use.

# SPARE PARTS OF ELECTRIC PROFURL NDE C 42

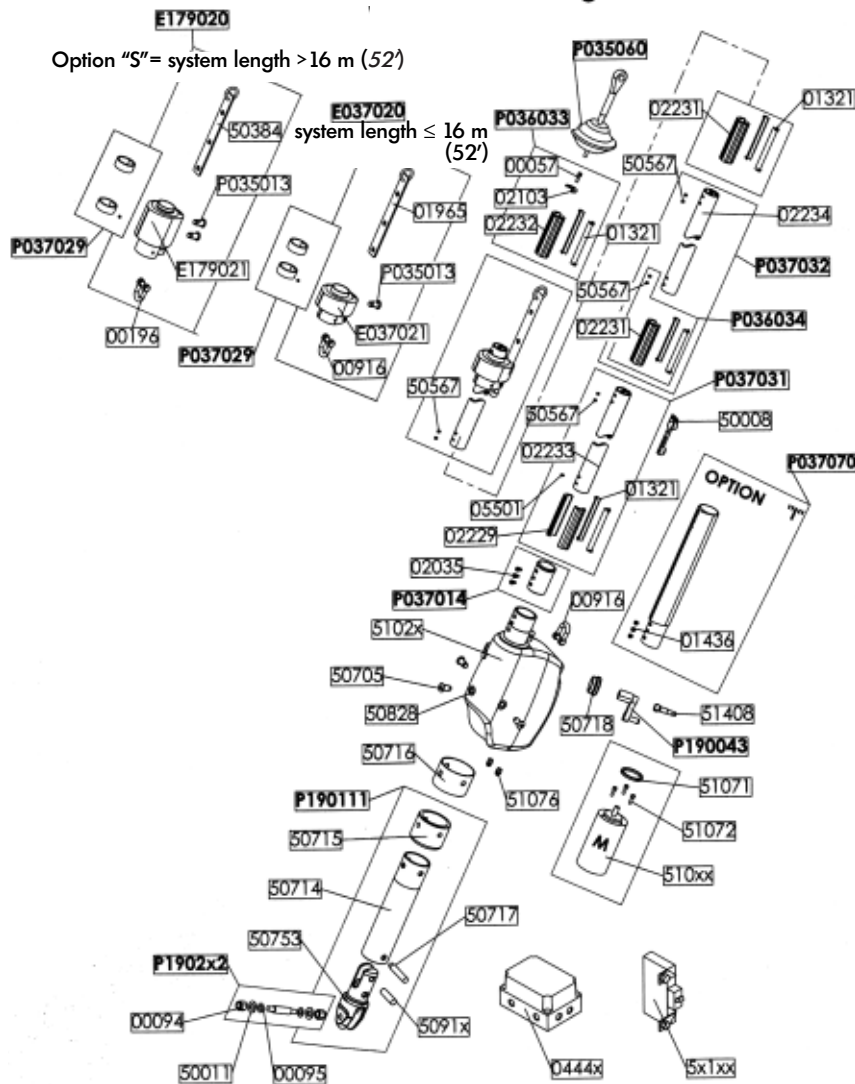
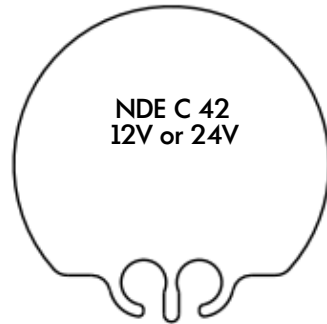

REF	PARTS LIST
P035060	WRAPSTOP
P036033	UPPER STOP
00057	Stop fixing screw
02103	Stop
02232	Upper bearing holder
01321	Plastic bearing 13mm (33/64") (two halves)
E037020	COMPLETE STANDARD SWIVEL
E037021	Standard swivel mechanism
01965	Standard swivel plate
P035013	Locked screw
P037029	Swivel bushing kit
00916	Shackle 8 mm
E179020	COMPLETE "S" HAILYARD SWIVEL
E179021	"S" swivel mechanism
50384	"S" swivel mechanism
P035013	Locked screw
P037029	Swivel bushing kit
00196	Shackle 10 mm
P037032	COMPLETE INTERMEDIATE EXTRUSION
02234	Intermediate extrusion
P036034	COMPLETE JOINING KIT
02231	Joining torque link
01321	Plastic bearing 13mm (33/64") (two halves)
50567	Teat screw ST Hc M6 X 10
P037031	COMPLETE LOWER EXTRUSION
02233	Lower extrusion
02229	Lower bearing holder (two halves)
01321	Plastic bearing 13mm (33/64") (two halves)
50567	Teat screw ST Hc M6 X 10
05501	Teat screw ST Hc M6 X 8
50008	Feeder
P190112	COMPLETE GEAR MOTOR 12 Volts (without fixing)
P190124	COMPLETE GEAR MOTOR 24 Volts (without fixing)
51025	Gear motor only 12 Volts
51024	Gear motor only 24 Volts
02035	Double teat lower extrusion stop screw
P037014	Shape adapter
51076	Stuffing box
51069	Electric motor 12 Volts 700 W
51070	Electric motor 24 Volts 800 W
51071	O ring 45 X 1,5
51072	Screw CHc M5
P50718	Handle socket cap
P190043	Handle
51408	Square drive for drilling-machine
P190111	FIXING
50705	Screw for stainless stell tube
50828	Spacer
50716	Anti corrosion bushing
50715	Stainless steel ring
50714	Stainless steel tube
50717	Tube attachment pin
50753	Toggle
50911	Clevis pin f 12
50912	Clevis pin f 12,7 (1/2")
50913	Clevis pin f 14 (9/16")
50914	Clevis pin f 16 (5/8")
50915	Clevis pin f 18
50916	Clevis pin f 19 (3/4")
50917	Clevis pin f 22 (7/8")
P190212	Chainplate threaded clevis pin f 12 w. nuts and Nylon washers
P190222	Chainplate threaded clevis pin f 12,7 (1/2") w. nuts and Nylon washers
P190232	Chainplate threaded clevis pin f 14 (9/16") w. nuts and Nylon washers
P190242	Chainplate threaded clevis pin f 16 (5/8") w. nuts and Nylon washers
P190252	Chainplate threaded clevis pin f 18 w. nuts and Nylon washers
P190262	Chainplate threaded clevis pin f 19 (3/4") w. nuts and Nylon washers
P190272	Chainplate threaded clevis pin f 22 (7/8") w. nuts and Nylon washers
00094	Locknut M12
00095	Stainless washer f 12mm
50011	Nylon washer f 12mm
P037070	Tumbuckle cylinder (OPTION "I")
01436	Teat lower extrusion stop screw
04446	Relay box 12 V
04447	Relay box 24 V
50162	Magneto thermic circuit breaker 12 volt
51157	Magneto thermic circuit breaker 24 volt

# SPARE PARTS OF ELECTRIC PROFURL NDE R 42

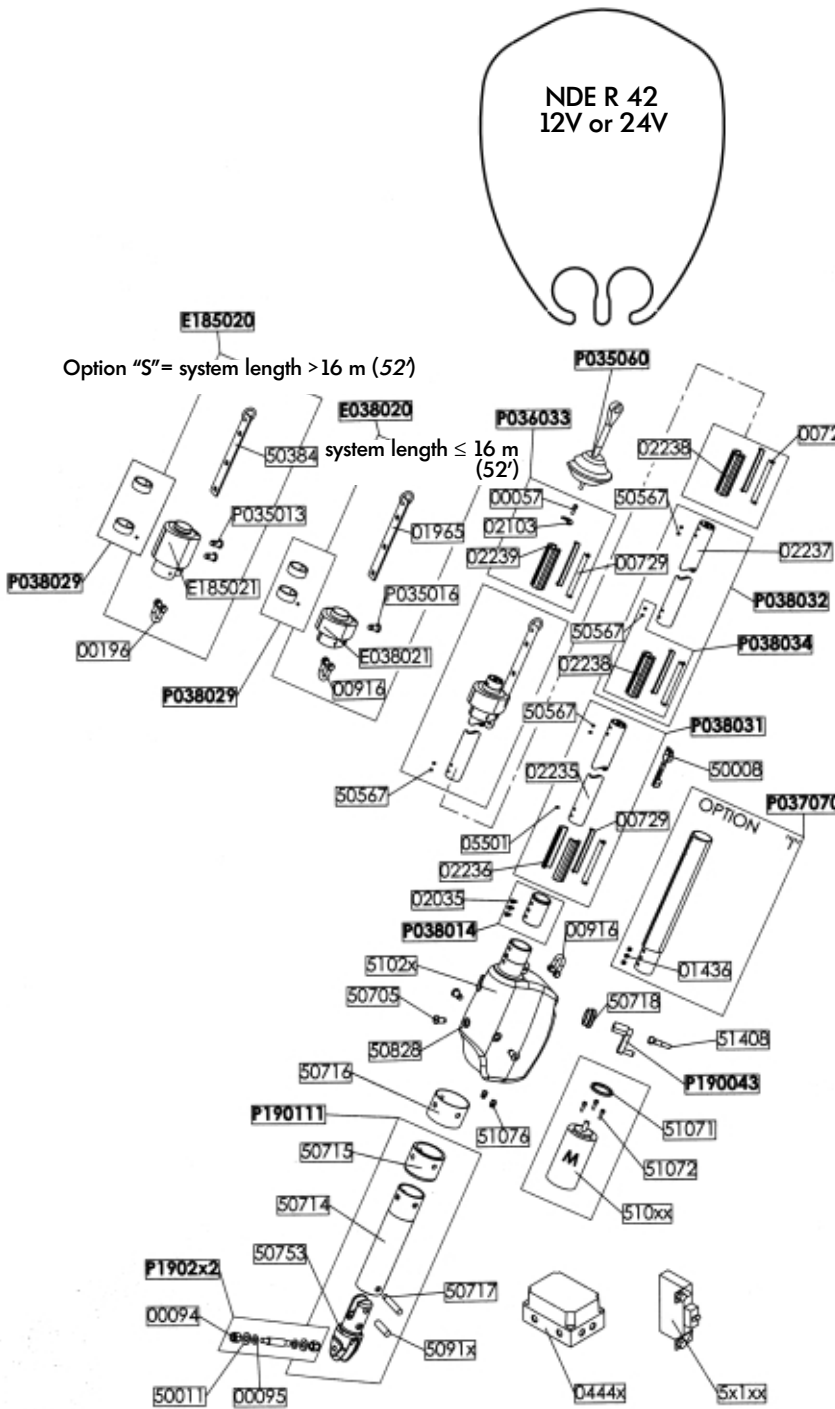

REF	PARTS LIST
P035060	WRAPSTOP
P036033	UPPER STOP
00057	Stop fixing screw
02103	Stop
02239	Upper bearing holder
00729	Plastic bearing 11mm (27/64") (two halves)
E038020	COMPLETE STANDARD SWIVEL
E038021	Standard swivel mechanism
01965	Standard swivel plate
P035013	Locked screw
P038029	Swivel bushing kit
00916	Shackle 8 mm
E179020	COMPLETE "S" HALYARD SWIVEL
E179021	"S" swivel mechanism
50384	"S" swivel mechanism
P035013	Locked screw
P038029	Swivel bushing kit
00196	Shackle 10 mm
P038032	COMPLETE INTERMEDIATE EXTRUSION
02237	Intermediate extrusion
P038034	COMPLETE JOINING KIT
02238	Joining torque link
00729	Plastic bearing 11mm (27/64") (two halves)
50567	Teat screw ST Hc M6 X 10
P038031	COMPLETE LOWER EXTRUSION
02235	Lower extrusion
02236	Lower bearing holder (two halves)
00729	Plastic bearing 11mm (27/64") (two halves)
50567	Teat screw ST Hc M6 X 10
05501	Teat screw ST Hc M6 X 8
50008	Feeder
P195112	COMPLETE GEAR MOTOR 12 Volts (without fixing)
P195124	COMPLETE GEAR MOTOR 24 Volts (without fixing)
51025	Gear motor only 12 Volts
51024	Gear motor only 24 Volts
02035	Double teat lower extrusion stop screw
P038014	Shape adapter
51076	Stuffing box
51069	Electric motor 12 Volts 700 W
51070	Electric motor 24 Volts 800 W
51071	O ring 45 X 1,5
51072	Screw CHc M5
P50718	Handle socket cap
P190043	Handle
51408	Square drive for drilling-machine
P190111	FIXING
50705	Screw for stainless stell tube
50828	Spacer
50716	Anti corrosion bushing
50715	Stainless steel ring
50714	Stainless steel tube
50717	Tube attachment pin
50753	Toggle
50911	Clevis pin f 12
50912	Clevis pin f 12,7 (1/2")
50913	Clevis pin f 14 (9/16")
50914	Clevis pin f 16 (5/8")
50915	Clevis pin f 18
50916	Clevis pin f 19 (3/4")
50917	Clevis pin f 22 (7/8")
P190212	Chainplate threaded devis pin f 12 w. nuts and Nylon washers
P190222	Chainplate threaded devis pin f 12,7 (1/2") w. nuts and Nylon washers
P190232	Chainplate threaded devis pin f 14 (9/16") w. nuts and Nylon washers
P190242	Chainplate threaded devis pin f 16 (5/8") w. nuts and Nylon washers
P190252	Chainplate threaded devis pin f 18 w. nuts and Nylon washers
P190262	Chainplate threaded devis pin f 19 (3/4") w. nuts and Nylon washers
P190272	Chainplate threaded devis pin f 22 (7/8") w. nuts and Nylon washers
00094	Locknut M12
00095	Stainless washer f 12mm
50011	Nylon washer f 12mm
P037070	Tumbuckle cylinder (OPTION "I")
01436	Teat lower extrusion stop screw
04446	Relay box 12 V
04447	Relay box 24 V
50162	Magneto thermic circuit breaker 12 volt
51157	Magneto thermic circuit breaker 24 volt

# SPARE PARTS OF ELECTRIC PROFURL NDE 52

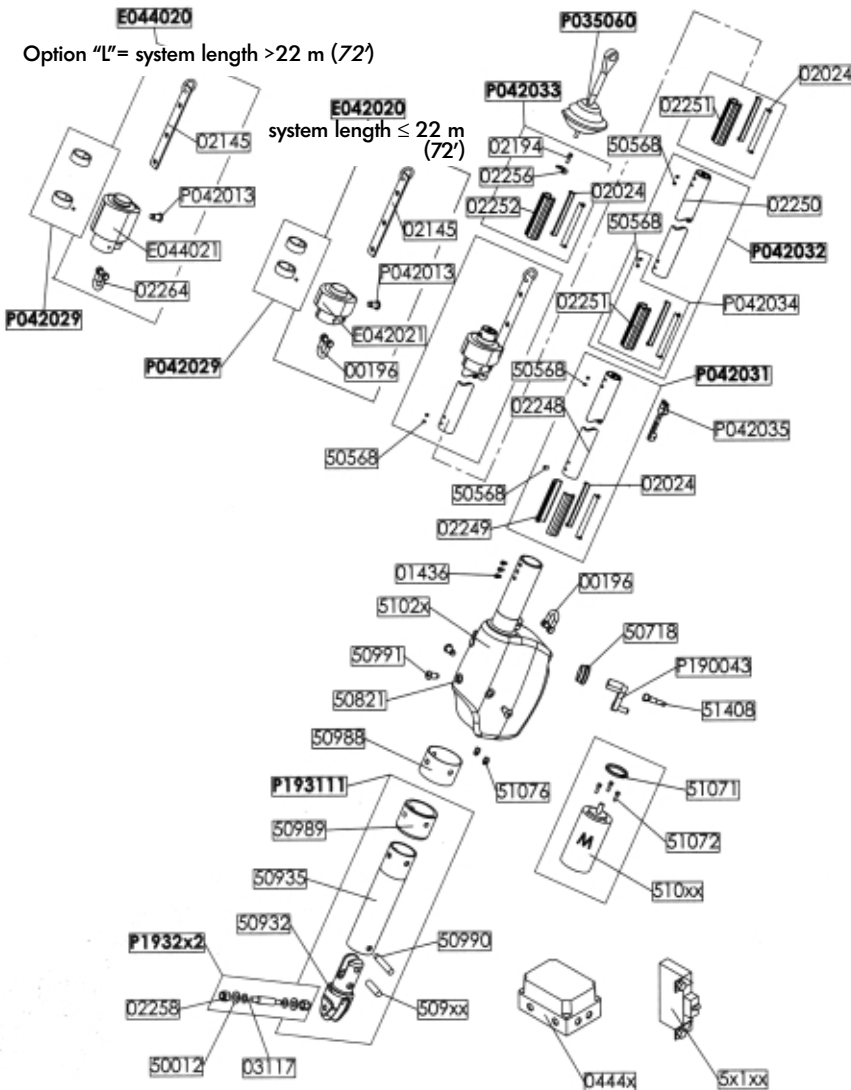
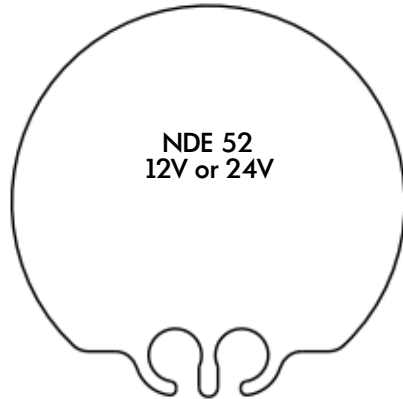

REF	PARTS LIST
P035060	WRAPSTOP
P042033	UPPER STOP
02194	Stop fixing screw
02256	Stop
02252	Upper bearing holder
02024	Plastic bearing 17mm (43/64") (two halves)
E042020	COMPLETE STANDARD SWIVEL
E042021	Standard swivel mechanism
02145	Standard swivel plate
P042013	Locked screw
P042029	Swivel bushing kit
00196	Shackle 8 mm
E044020	COMPLETE "S" HAILYARD SWIVEL
E044021	"S" swivel mechanism
02145	"S" swivel mechanism
P042013	Locked screw
P042029	Swivel bushing kit
02264	Shackle 8 mm
P042032	COMPLETE INTERMEDIATE EXTRUSION
02250	Intermediate extrusion
P042034	COMPLETE JOINING KIT
02251	Joining torque link
02024	Plastic bearing 17mm (43/64") (two halves)
50568	Test screw ST Hc M6 X 10
P042031	COMPLETE LOWER EXTRUSION
02248	Lower extrusion
02249	Lower bearing holder (two halves)
02024	Plastic bearing 17mm (43/64") (two halves)
50568	Test screw ST Hc M6 X 10
P042035	Feeder
P193112	COMPLETE GEAR MOTOR 12 Volts (without fixing)
P193124	COMPLETE GEAR MOTOR 24 Volts (without fixing)
51025	Gear motor only 12 Volts
51024	Gear motor only 24 Volts
01436	Double teat lower extrusion stop screw
51076	Stuffing box
51069	Electric motor 12 Volts 700 W
51070	Electric motor 24 Volts 800 W
51071	O ring 45 X 1,5
51072	Screw CHc M5
P50718	Handle socket cap
P190043	Handle
51408	Square drive for drilling-machine
P193111	FIXING
50991	Screw for stainless stell tube
50821	Spacer
50988	Anti corrosion bushing
50989	Stainless steel ring
50935	Stainless steel tube
50990	Tube attachment pin
50932	Toggle
50918	Clevis pin f 16mm (5/8")
50919	Clevis pin f 18mm
50920	Clevis pin f 19mm (3/4")
50921	Clevis pin f 22mm (7/8")
50922	Clevis pin f 25mm (1")
50923	Clevis pin f 27mm (1 1/16)
50924	Clevis pin f 29mm (1 9/64)
P193212	Chainplate threaded clevis pin f 16mm (5/8") with nuts and washers
P193222	Chainplate threaded clevis pin f 18mm with nuts and washers
P193232	Chainplate threaded clevis pin f 19mm (3/4") with nuts and washers
P193242	Chainplate threaded clevis pin f 22mm (7/8") with nuts and washers
P193252	Chainplate threaded clevis pin f 25mm (1") with nuts and washers
P193262	Chainplate threaded clevis pin f 27mm (1 1/16) with nuts and washers
P193272	Chainplate threaded clevis pin f 29mm (1 9/64) with nuts and washers
02258	Locknut M14
03117	Stainless washer f 14mm
50012	Nylon washer f 14mm
04446	Relay box 12 V
04447	Relay box 24 V
50162	Magneto thermic circuit breaker 12 volt
51157	Magneto thermic circuit breaker 24 volt

# SPARE PARTS OF HYDRAULIC PROFURL NDH C 42

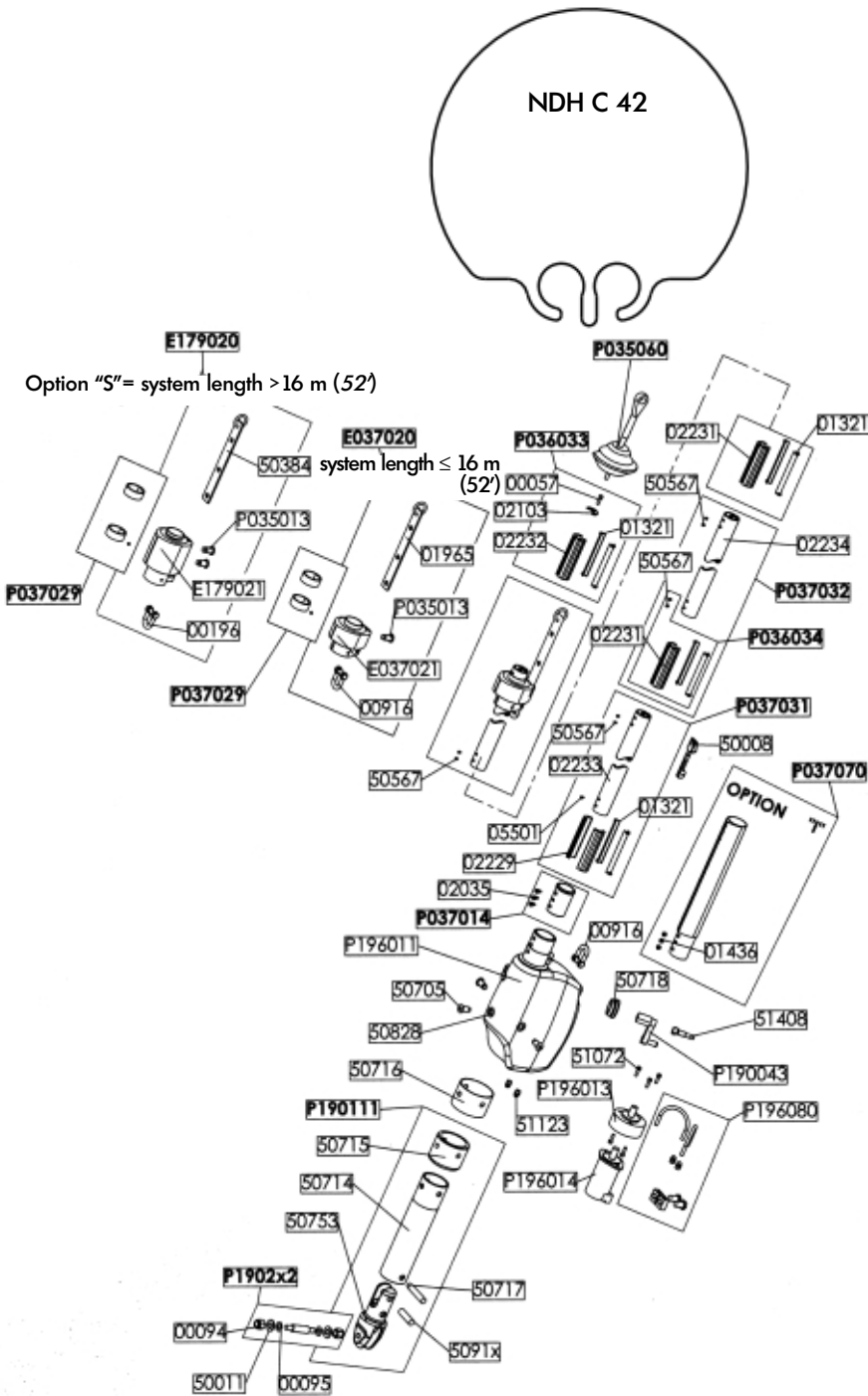

REF	PARTS LIST
P035060	WRAPSTOP
P036033	UPPER STOP
00057	Stop fixing screw
02103	Stop
02232	Upper bearing holder
01321	Plastic bearing 13mm (33/64") (two halves)
E037020	COMPLETE STANDARD SWIVEL
E037021	Standard swivel mechanism
01965	Standard swivel plate
P035013	Locked screw
P037029	Swivel bushing kit
00916	Shackle 8 mm
E179020	COMPLETE "S" HALLYARD SWIVEL
E179021	"S" swivel mechanism
50384	"S" swivel mechanism
P035013	Locked screw
P037029	Swivel bushing kit
00196	Shackle 10 mm
P037032	COMPLETE INTERMEDIATE EXTRUSION
02234	Intermediate extrusion
P036034	COMPLETE JOINING KIT
02231	Joining torque link
01321	Plastic bearing 13mm (33/64") (two halves)
50567	Teat screw ST Hc M6 X 10
P037031	COMPLETE LOWER EXTRUSION
02233	Lower extrusion
02229	Lower bearing holder (two halves)
01321	Plastic bearing 13mm (33/64") (two halves)
50567	Teat screw ST Hc M6 X 10
05501	Teat screw ST Hc M6 X 8
50008	Feeder
P196112	COMPLETE GEAR MOTOR (without fixing)
P196011	Gear motor only ( no lower fittings )
02035	Double teat lower extrusion stop screw
P037014	Shape adapter
51123	Outlet connector 7/16" JIC
P196014	Hydraulic motor only
P196013	Hydraulic motor adapter
P196080	Tube fittings and connector
51072	Screw CHc M5
P50718	Handle socket cap
P190043	Handle
51408	Square drive for drilling-machine
P190111	FIXING
50705	Screw for stainless stell tube
50828	Spacer
50716	Anti corrosion bushing
50715	Stainless steel ring
50714	Stainless steel tube
50717	Tube attachment pin
50753	Toggle
50911	Clevis pin f 12
50912	Clevis pin f 12,7 (1/2")
50913	Clevis pin f 14 (9/16")
50914	Clevis pin f 16 (5/8")
50915	Clevis pin f 18
50916	Clevis pin f 19 (3/4")
50917	Clevis pin f 22 (7/8")
P190212	Chainplate threaded clevis pin f 12 w. nuts and Nylon washers
P190222	Chainplate threaded clevis pin f 12,7 (1/2") w. nuts and Nylon washers
P190232	Chainplate threaded clevis pin f 14 (9/16") w. nuts and Nylon washers
P190242	Chainplate threaded clevis pin f 16 (5/8") w. nuts and Nylon washers
P190252	Chainplate threaded clevis pin f 18 w. nuts and Nylon washers
P190262	Chainplate threaded clevis pin f 19 (3/4") w. nuts and Nylon washers
P190272	Chainplate threaded clevis pin f 22 (7/8") w. nuts and Nylon washers
00094	Locknut M12
00095	Stainless washer f 12mm
50011	Nylon washer f 12mm
P037070	Tumbuckle cylinder (OPTION 'I')
01436	Teat lower extrusion stop screw



# SPARE PARTS OF HYDRAULIC PROFURL NDH R 42

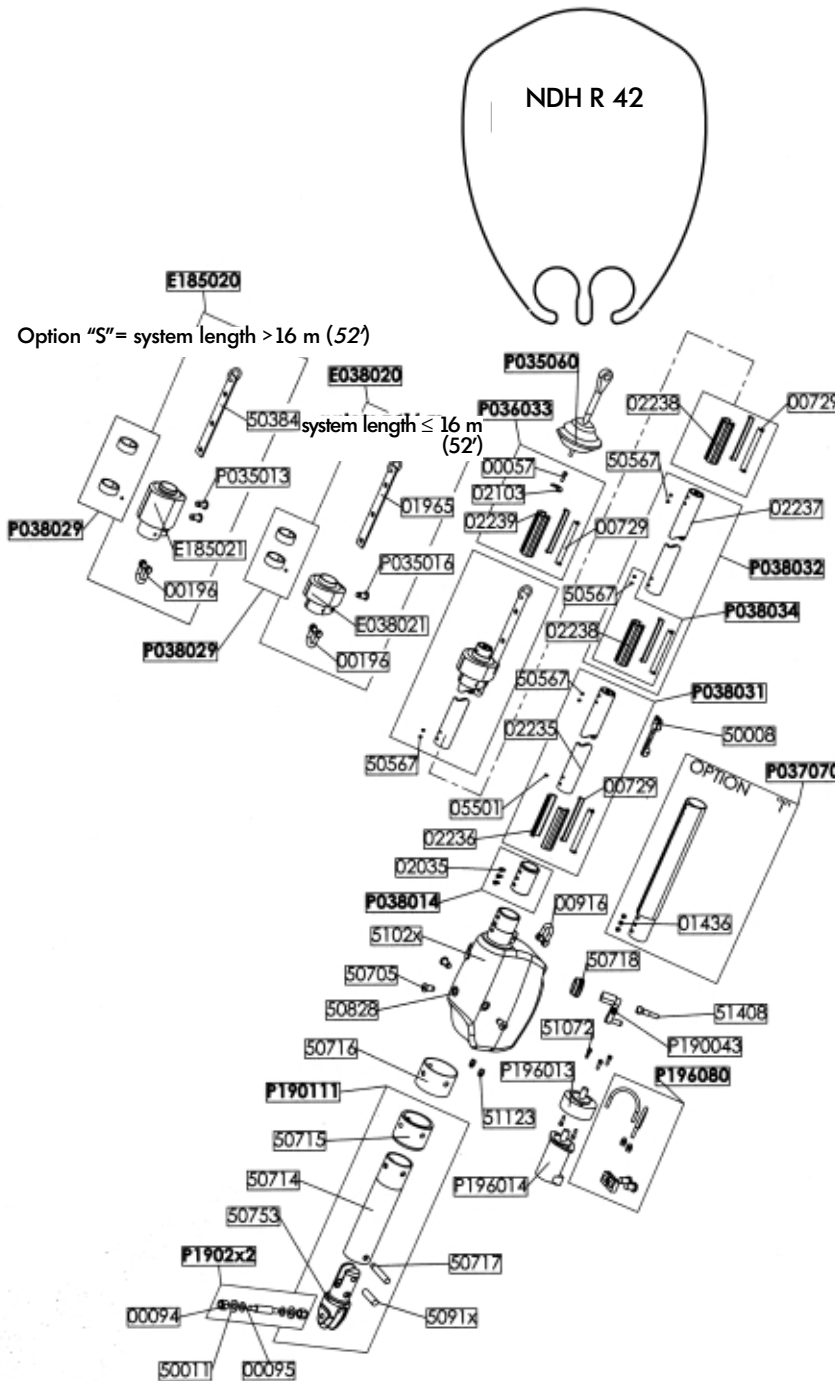

REF	PARTS LIST
P035060	WRAPSTOP
P036033	UPPER STOP
00057	Stop fixing screw
02103	Stop
02239	Upper bearing holder
00729	Plastic bearing 11mm (27/64") (two halves)
E038020	COMPLETE STANDARD SWIVEL
E038021	Standard swivel mechanism
01965	Standard swivel plate
P035013	Locked screw
P038029	Swivel bushing kit
00916	Shackle 8 mm
E179020	COMPLETE "S" HALLYARD SWIVEL
E179021	"S" swivel mechanism
50384	"S" swivel mechanism
P035013	Locked screw
P038029	Swivel bushing kit
00196	Shackle 10 mm
P038032	COMPLETE INTERMEDIATE EXTRUSION
02237	Intermediate extrusion
P038034	COMPLETE JOINING KIT
02238	Joining torque link
00729	Plastic bearing 11mm (27/64") (two halves)
50567	Teat screw ST Hc M6 X 10
P038031	COMPLETE LOWER EXTRUSION
02235	Lower extrusion
02236	Lower bearing holder (two halves)
00729	Plastic bearing 11mm (27/64") (two halves)
50567	Teat screw ST Hc M6 X 10
05501	Teat screw ST Hc M6 X8
50008	Feeder
P197112	COMPLETE GEAR MOTOR (without fixing)
P196011	Gear motor only ( no lower fittings )
02035	Double teat lower extrusion stop screw
P038014	Shape adapter
51123	Outlet connector 7/16" JIC
P196014	Hydraulic motor only
P196013	Hydraulic motor adapter
P196080	Tube fittings and connector
51072	Screw CHc M5
P50718	Handle socket cap
P190043	Handle
51408	Square drive for drilling-machine
P190111	FIXING
50705	Screw for stainless stell tube
50828	Spacer
50716	Anti corrosion bushing
50715	Stainless steel ring
50714	Stainless steel tube
50717	Tube attachment pin
50753	Toggle
50911	Clevis pin f 12
50912	Clevis pin f 12,7 (1/2")
50913	Clevis pin f 14 (9/16")
50914	Clevis pin f 16 (5/8")
50915	Clevis pin f 18
50916	Clevis pin f 19 (3/4")
50917	Clevis pin f 22 (7/8")
P190212	Chainplate threaded clevis pin f 12 w. nuts and Nylon washers
P190222	Chainplate threaded clevis pin f 12,7 (1/2") w. nuts and Nylon washers
P190232	Chainplate threaded clevis pin f 14 (9/16") w. nuts and Nylon washers
P190242	Chainplate threaded clevis pin f 16 (5/8") w. nuts and Nylon washers
P190252	Chainplate threaded clevis pin f 18 w. nuts and Nylon washers
P190262	Chainplate threaded clevis pin f 19 (3/4") w. nuts and Nylon washers
P190272	Chainplate threaded clevis pin f 22 (7/8") w. nuts and Nylon washers
00094	Locknut M12
00095	Stainless washer f 12mm
50011	Nylon washer f 12mm
P037070	Tumbuckle cylinder (OPTION "I")
01436	Teat lower extrusion stop screw

# SPARE PARTS OF HYDRAULIC PROFURL NDH 52

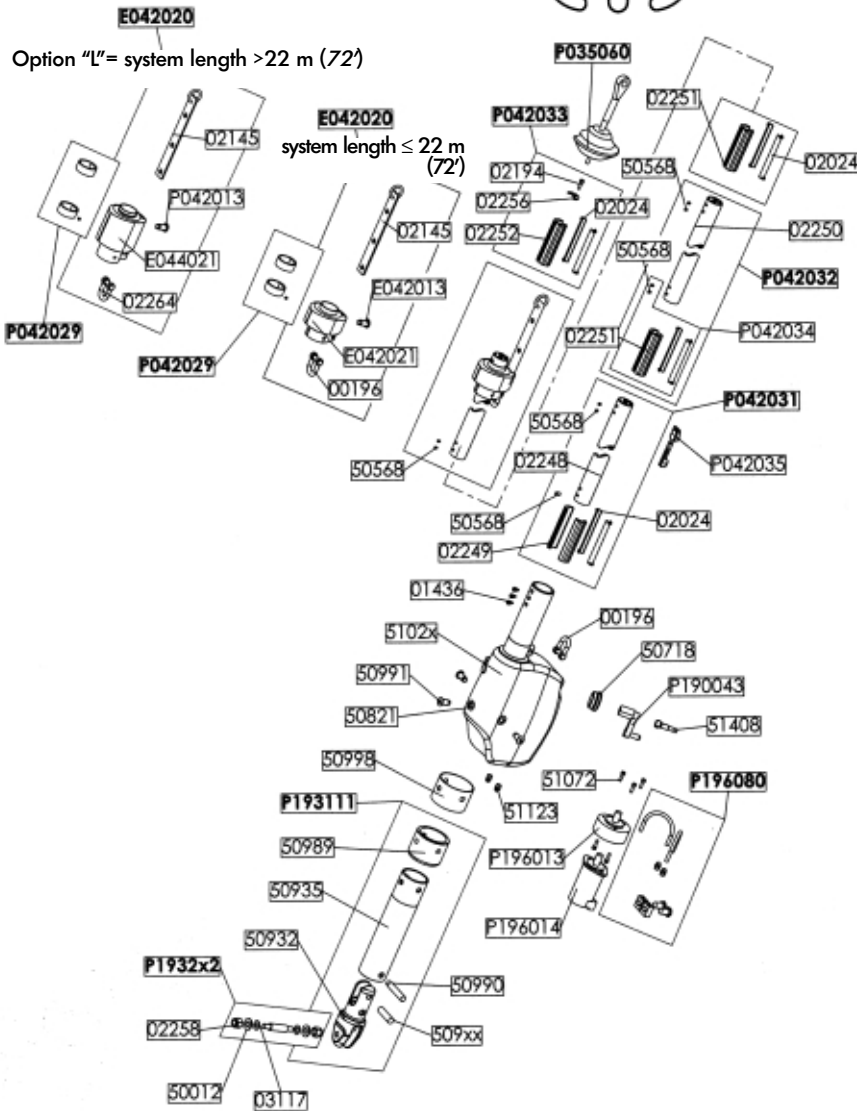
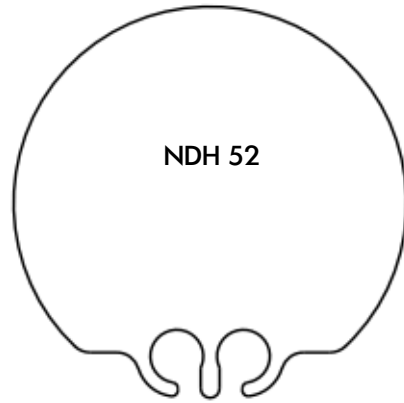

REF	PARTS LIST
P035060	WRAPSTOP
P042033	UPPER STOP
02194	Stop fixing screw
02256	Stop
02252	Upper bearing holder
02024	Plastic bearing 17mm (43/64") (two halves)
E042020	COMPLETE STANDARD SWIVEL
E042021	Standard swivel mechanism
02145	Standard swivel plate
P042013	Locked screw
P042029	Swivel bushing kit
00196	Shackle 8 mm
E044020	COMPLETE 'S' HAILYARD SWIVEL
E044021	'S' swivel mechanism
02145	'S' swivel mechanism
P042013	Locked screw
P042029	Swivel bushing kit
02264	Shackle 8 mm
P042032	COMPLETE INTERMEDIATE EXTRUSION
02250	Intermediate extrusion
P042034	COMPLETE JOINING KIT
02251	Joining torque link
02024	Plastic bearing 17mm (43/64") (two halves)
50568	Teat screw ST Hc M6 X 10
P042031	COMPLETE LOWER EXTRUSION
02248	Lower extrusion
02249	Lower bearing holder (two halves)
02024	Plastic bearing 17mm (43/64") (two halves)
50568	Teat screw ST Hc M6 X 10
P042035	Feeder
P198112	COMPLETE GEAR MOTOR (without fixing)
P196011	Gear motor only ( no lower fittings )
02035	Double teat lower extrusion stop screw
51123	Outlet connector 7/16" JIC
P196014	Hydraulic motor only
P196013	Hydraulic motor adapter
P198080	Tube fittings and connector
51072	Screw CHc M5
P50718	Handle socket cap
P190043	Handle
51408	Square drive for drilling-machine
P193111	FIXING
50991	Screw for stainless stell tube
50821	Spacer
50988	Anti corrosion bushing
50989	Stainless steel ring
50935	Stainless steel tube
50990	Tube attachment pin
50932	Toggle
50918	Clevis pin f 16mm (5/8")
50919	Clevis pin f 18mm
50920	Clevis pin f 19mm (3/4")
50921	Clevis pin f 22mm (7/8")
50922	Clevis pin f 25mm (1")
50923	Clevis pin f 27mm (1 1/16)
50924	Clevis pin f 29mm (1 9/64)
P193212	Chainplate threaded clevis pin f 16mm (5/8") with nuts and washers
P193222	Chainplate threaded clevis pin f 18mm with nuts and washers
P193232	Chainplate threaded clevis pin f 19mm (3/4") with nuts and washers
P193242	Chainplate threaded clevis pin f 22mm (7/8") with nuts and washers
P193252	Chainplate threaded clevis pin f 25mm (1") with nuts and washers
P193262	Chainplate threaded clevis pin f 27mm (1 1/16) with nuts and washers
P193272	Chainplate threaded clevis pin f 29mm (1 9/64) with nuts and washers
02258	Locknut M14
03117	Stainless washer f 14mm
50012	Nylon washer f 14mm

# DIMENSIONS OF MOTORIZED PROFURL SYSTEMS

## models 42

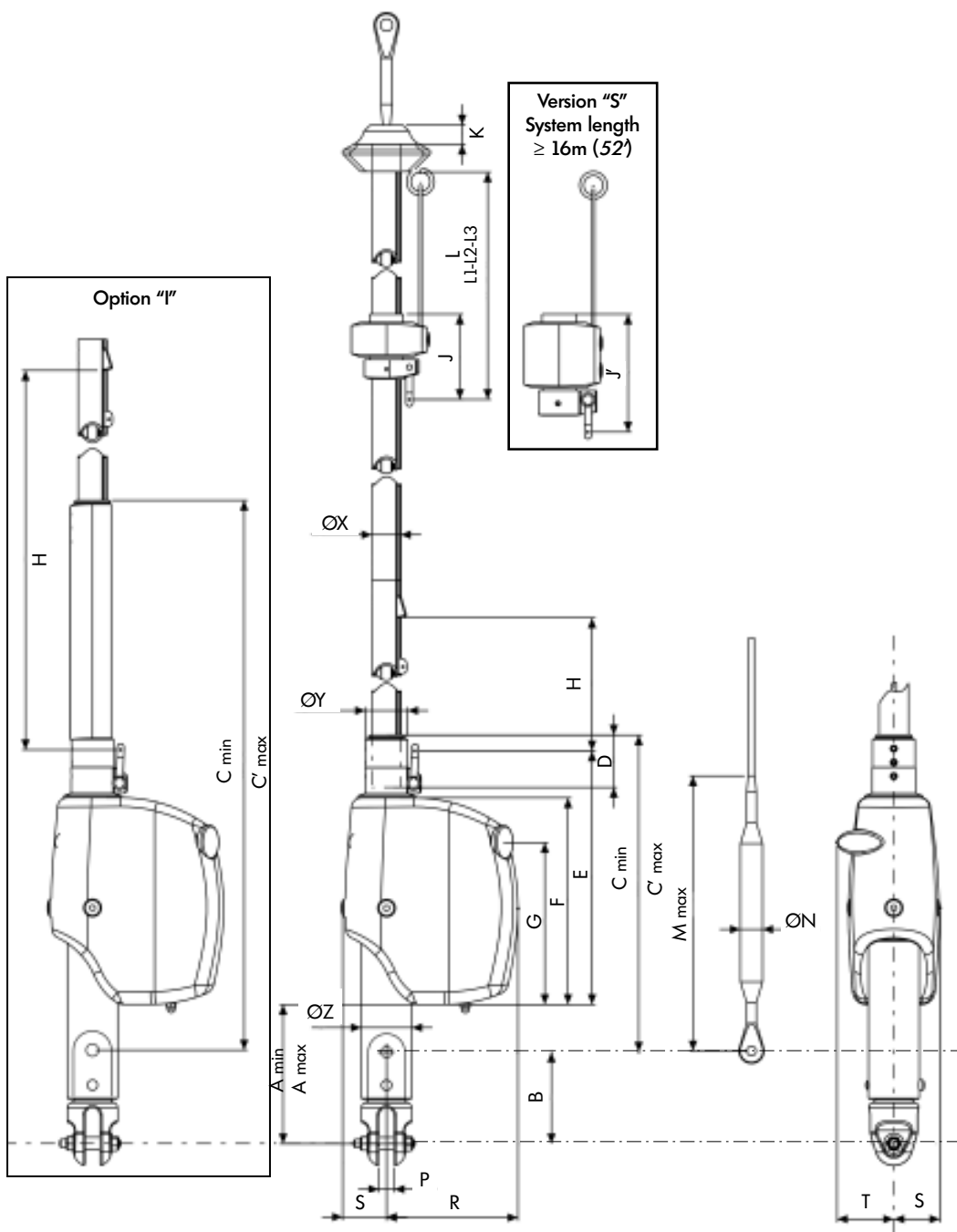

	Standard		Option "I"	
	mm	ins	mm	ins
A min	110	4 21/64"	110	4 21/64"
A max	200	7 7/8"	200	7 7/8"
B	133	5 15/64"	133	5 15/64"
C min	380	11 13/16"	725	2' 4 35/64"
C max	470	1' 6 1/2"	815	32 3/32"
D	82	3 7/32"	82	3 7/32"
E	385	1' 3 5/32"	385	1' 3 5/32"
F	310	1' 13/64"	310	1' 13/64"
G	246	9 11/16"	246	9 11/16"
H	530	1' 8 7/8"	875	2' 10 29/64"
J	129	5' 5/64"	129	5 5/64"
J'	166	6 17/32"	166	6 17/32"
K	28	1 7/64"	28	1 7/64"
L 1*	161	6 11/32"	161	6 11/32"
L 2*	251	9 7/8"	251	9 7/8"
L 3*	331	13 1/32"	331	1' 1 1/32"
M max	385	2' 4 15/32"	723	2' 4 15/32"
N max	40	1 37/64"	40	1 37/64"
P	22	7/8"	22	7/8"
R	170	6 11/16"	170	6 11/16"
S	62	2 7/16"	62	2 7/16"
T	90	3 35/64"	90	3 35/64"
Ø X	42	1 21/32"	42	1 21/32"
Ø Y	61	2 13/32"	61	2 13/32"
Ø Z	73	2 7/8"	73	2 7/8"

\* adjustable

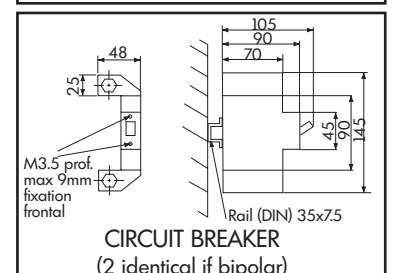
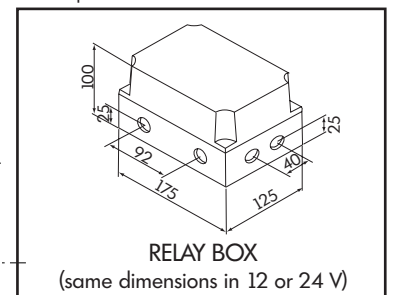

- Finished luff tape diameter: 5 mm (3/16") -

# DIMENSIONS OF MOTORIZED PROFURL SYSTEMS models 52

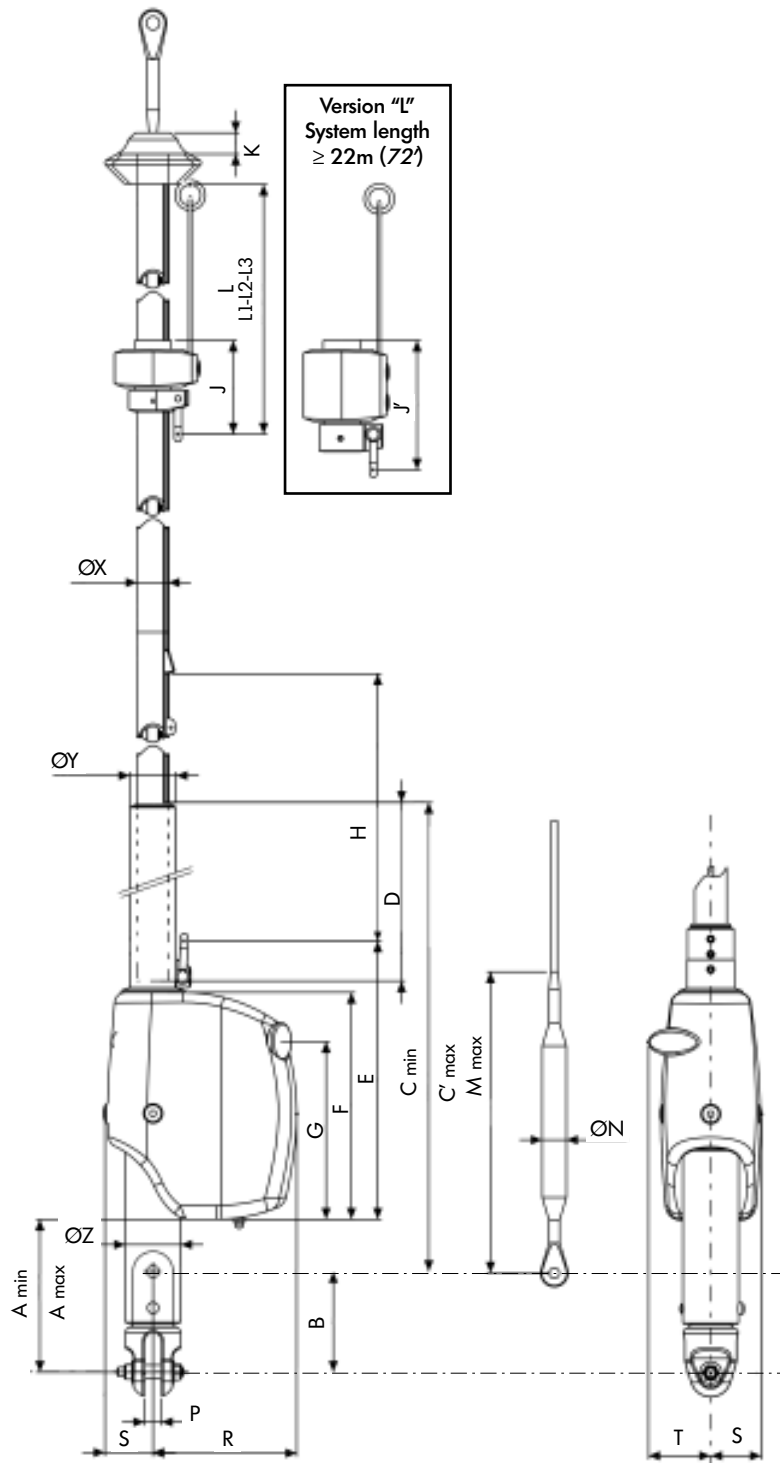

- Finished luff tape diameter: 6 mm (15/64") -

	mm	ins
A min	130	5 1/8"
A' max	327	1' 7/8"
B	150	5 29/32"
C min	640	2' 3 13/64"
C' max	836	2' 8 29/32"
D	105	4 1/8"
E	398	1' 3 11/16"
F	315	1' 13/32"
G	250	9 27/32"
H	850	2' 9 15/32"
J	173	6 13/16"
J'	186	7 5/16"
K	28	1 1/64"
L 1*	329	1' 61/64"
L 2*	429	1' 4 57/64"
L 3*	529	1' 8 53/64"
M max	730	28 3/4"
N max	50	1 15/16"
P	28	1 1/64"
R	195	7 11/16"
S	77	3 3/64"
T	100	3 15/16"
Ø X	52	2 3/64"
Ø Y	66	2 39/64"
Ø Z	88	2 7/8"

\* adjustable

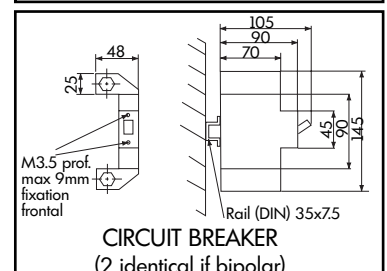
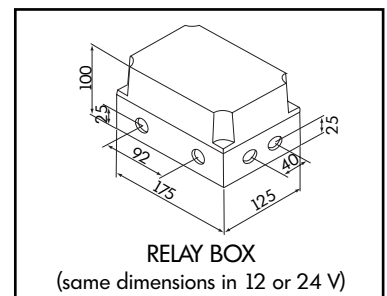

## **CONDITIONS DE GARANTIE**

Sans préjudice de la garantie légale, votre produit PROFURL est garanti 3 (trois) ans à partir de la date de sa mise en service, la facture d'achat au revendeur ou au constructeur faisant foi.

La garantie se limite au remplacement ou à la réparation en nos ateliers des pièces reconnues défectueuses.

La garantie disparaît immédiatement et complètement si le client modifie ou fait réparer sans l'accord de Wichard le matériel fourni. La réparation, la modification ou le remplacement des pièces pendant la période de garantie ne peuvent avoir pour effet de prolonger le délai de garantie du matériel.

La garantie ne couvre pas les dommages consécutifs à un mauvais montage, à une utilisation inappropriée ou abusive, à un accident ou à toute fortune de mer.

## **PROCEDURE A SUIVRE EN CAS D'APPEL EN GARANTIE**

En cas d'impossibilité de faire constater par une personne compétente la nature des dommages, le client prendra contact directement avec WICHARD S.A. - France.

La ou les pièce(s) défectueuse(s) devra (devront) impérativement être retournée(s) pour inspection à WICHARD S.A.S (France), à WICHARD, Inc aux USA ou à WICHARD PACIFIC Pty Ltd, port aux frais du client, dans les 14 (quatorze) jours suivant le constat de l'avarie.

En cas de réexpédition du matériel depuis un pays tiers, les frais de dédouanement éventuels correspondant à l'entrée en France ou aux USA restent à la charge du client.

Au cas où le client exige une réexpédition des pièces avant réception des pièces défectueuses par WICHARD S.A.S (France), WICHARD Inc (USA) ou WICHARD PACIFIC Pty, celles-ci seront facturées et payables avant l'expédition, règlement par carte bancaire, transfert bancaire ou tout autre moyen. Si la responsabilité de WICHARD est reconnue, WICHARD remboursera le client dans les meilleurs délais.

---

## **LIMITED WARRANTY**

*Your PROFURL product is warranted for a period of 3 (three) year from the date of purchase against parts and materials.*

*This warranty is limited to the repair and replacement of defective parts by an authorized PROFURL dealer and only after the written consent of WICHARD S.A.S (France), WICHARD Inc, or WICHARD PACIFIC (addresses below).*

*The warranty is void if the system is modified or repaired prior written consent of WICHARD S.A.S (France), WICHARD Inc or WICHARD PACIFIC.*

*This warranty covers only the WICHARD parts and materials. Any accidental damage or expenses are not covered by the warranty.*

*This warranty does not cover damages caused by a system which was installed or used improperly, damaged by collision, or any act of God.*

*In the event of a warranty claim, WICHARD's liability is limited to the value of the system at the date of purchase. Packaging costs, shipment or custom charges are at customer's expense.*

## **WHICH PROCEDURE SHOULD YOU FOLLOW IN CASE OF WARRANTY CLAIM?**

- In case it is impossible for the owner to have the damage checked by a skilled person, the owner will contact WICHARD S.A.S (France), WICHARD, Inc (USA) or WICHARD PACIFIC Pty Ltd. Please see address below.*
- The defective part should be returned at owner's expenses to WICHARD S.A.S (France), WICHARD Inc or WICHARD PACIFIC Pty Ltd within 14 (fourteen) days after the damage occurred to the system.*
- In case the parts are shipped from a country outside France, USA or Australia, custom duties for return to WICHARD should be prepaid by the owner.*
- In case the owner will demand urgent replacement of part before the defective part is received by WICHARD, the replacement part will be charged to the owner, and paid before shipping (credit cards accepted). In case WICHARD's responsibility is finally acknowledged, WICHARD will refund the owner.*
- No replacement part purchased from a PROFURL dealer will be refunded to the owner.*
- In the normal warranty procedure, the parts will be returned to the owner, shipping and customs at owner's expenses.*

**[www.profurl.com](http://www.profurl.com)**

**WICHARD France**

Hotline / Support technique / SAV  
33 rue de l'Etoile du matin  
44600 Saint Nazaire,  
France  
Tel +33 (0)2 51 76 00 35  
Fax +33 (0)2 40 01 40 43  
Email : [hotline@wichard.com](mailto:hotline@wichard.com)

**WICHARD, Inc**

47 High Point Ave  
Portsmouth RI 02871,  
USA  
Tel : +1 401 683 5055  
Fax : +1 401 683 5077  
Free toll number: + 1 800 852-7084  
Email : [info@wichard-usa.com](mailto:info@wichard-usa.com)

**WICHARD PACIFIC Pty Ltd**

Unit 13, 2 Bishop Street  
St Peters NSW 2044,  
Australia  
Tel : + 61 2 9516 0677  
Fax : + 61 2 9516 0688  
Freecall from Australia: 1800 639 767  
Email : [don@wichard.com.au](mailto:don@wichard.com.au)